

## Lift and Turn Compression Latch

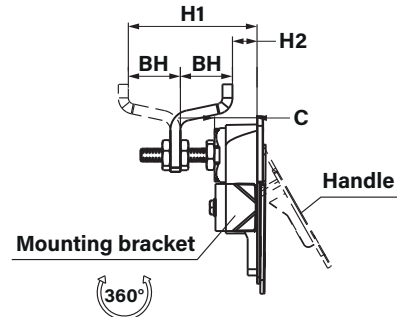

ZINC

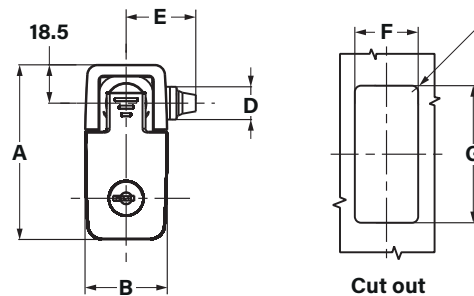

Lift and Turn Compression Latch in black. Adjustable grip range 6-16mm and 56-66mm.

Suitable applications include switchgear panels, electric cabinets, telecommunication cabinets, machine equipment, ATM machines, automotive, electronic enclosures, industrial enclosures, HVAC and trucks.

- Zinc die handle
- Black powder coated housing
- Mild steel zinc plated cam and shaft

Part No.	A	B	C	D	E	F	G
60223	85	40	21	16	34	29.5	72.5

All dimensions shown in mm unless otherwise stated. We reserve the right to alter specifications without notice.



Thousands of products available to buy online



Reliable international delivery service



The UK's leading stockist of locks, handles, hinges gas springs & accessories

Order online at  
[www.faparkes.co.uk](http://www.faparkes.co.uk)

Your *One-Stop-Shop* for all your hardware requirements!



FA Parkes Ltd  
Unit 4, Acorn Court  
Butts Street,  
Leigh  
Lancashire, UK  
WN7 3AE



+44 (0) 1942 681 996



+44 (0) 1942 681 997



[www.faparkes.co.uk](http://www.faparkes.co.uk)



[sales@faparkes.co.uk](mailto:sales@faparkes.co.uk)

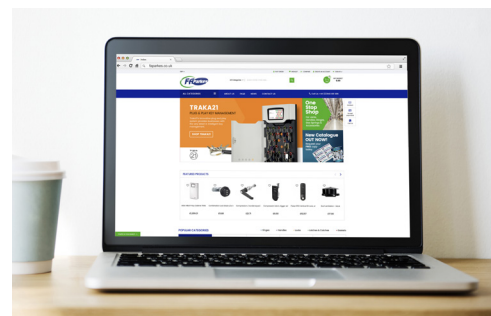

- Search by keyword or part number
- Browse by part type
- Product datasheet downloads
- No sign up required!

