

Mechanical Combination Lock

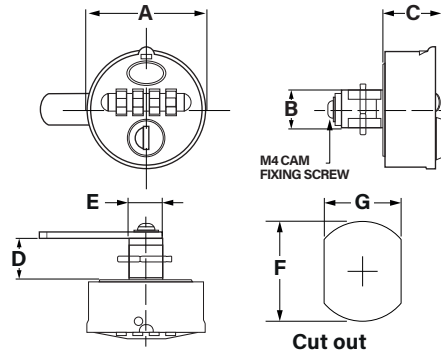

The Mechanical Combination Lock is a 4 wheel combination lock featuring up to 10,000 unique combinations. With a robust design, range of options and simplicity of use this lock is suitable for a broad range of applications including lockers and office furniture.



- 10,000 lock combinations
- Code finding feature
- LH / RH

Part No.	A	B	C	D	E	F	G
59893	Ø56	Ø19	28	20	15.9 A/F	Ø19.1 MIN	16.0 A/F MIN

All dimensions shown in mm unless otherwise stated. We reserve the right to alter specifications without notice.



Thousands of products available to buy online



Reliable international delivery service



The UK's leading stockist of locks, handles, hinges gas springs & accessories

Order online at

www.faparkes.co.uk

Your *One-Stop-Shop* for all your hardware requirements!



F.A.PARKES (MOTOR BODY FITTINGS) LIMITED
Unit 4, Acorn Court
Butts Street,
Leigh, Lancashire, UK
WN7 3AE



+44 (0) 1942 681 996



+44 (0) 1942 681 997



www.faparkes.co.uk



sales@faparkes.co.uk

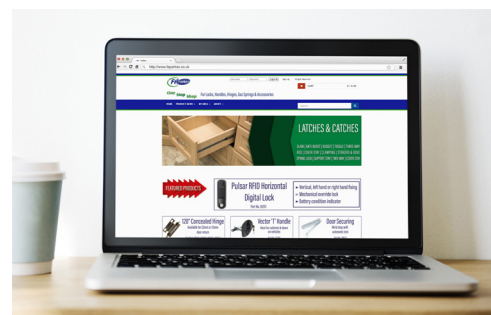

- Search by keyword or part number
- Browse by part type
- Product datasheet downloads
- No sign up required!

