

Drawer Slide - Heavy Duty (Corrosion Resistant)

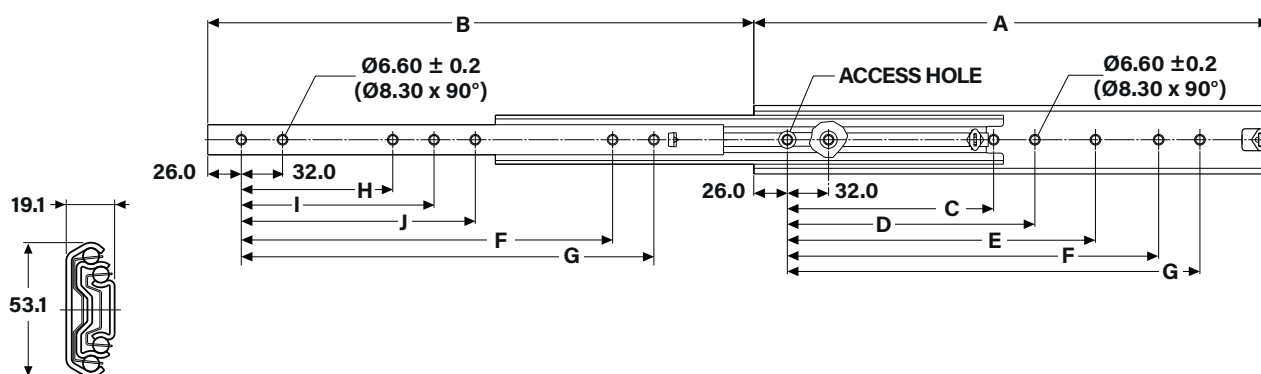

These Heavy Duty Drawer Slides are the perfect solution for fixtures in commercial kitchens and industrial or outdoor cabinetry that is exposed to the elements due to its specially-engineered corrosion-resistant hardware.

These stainless steel slides have L-shaped brackets with locator pins for a seamless disconnect and a load rating of upto 140kg/160kg.

- Load rating up to 140/160kg
- 100% extension
- 19.1mm slide thickness
- Hold-in
- Vertical (side) mounting only

(Table ref. "kg": W = Weight L = Load)

Part No.	A	B	C	D	E	F	G	H	I	J	kg		
											W	L	L
52436	300	323.5	-	-	-	192	224	-	-	-	1.73	130	120
52437	350	373.5	-	-	-	224	256	-	-	-	2.04	140	120
52438	400	423.5	-	160	192	288	320	128	160	-	2.34	150	130
52439	450	473.5	-	160	192	320	352	128	160	-	2.64	160	140
52440	500	523.5	-	192	224	384	416	160	192	-	2.94	160	140
52441	550	573.5	-	192	224	416	448	160	192	-	3.25	160	140
52442	600	623.5	-	256	288	480	512	192	256	-	3.55	150	120
52443	700	723.5	288	320	544	576	608	256	288	544	4.16	130	110
52444	790	803.5	-	352	384	672	704	320	352	384	4.72	100	100
59640	900	923.5	-	448	480	768	800	352	384	416	5.33	90	80
59639	1100	1123.5	448	544	576	992	1024	448	480	512	6.39	70	60

All dimensions shown in mm unless otherwise stated. We reserve the right to alter specifications without notice.

Order online at
www.faparkes.co.uk

