

Universal LH / RH

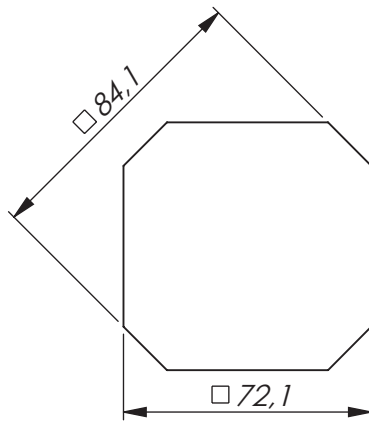

Specifications subject to change without notice

## SQUARE LATCH FOR CLIP-IN MOUNTING

Square latch for clip-in mounting and rod latches. Quick rod attachment. Cam rotation is 90° clockwise or counter-clockwise. Universal right and left mounting in a door thickness of 0,8 - 1,0 mm. The cylinder has 1000 key combinations. Supplied with two keys. Key extraction: Open / closed. Master key system on request.

Rods: Page 2-540 and 2-541.  
Rod guides: Page 2-560 and 2-570.

### MATERIAL:

Housing: Glass fibre reinforced polyamide (PA6), black.  
Handle: Zinc die-cast, silver-grey coated.  
Cylinder: Zinc die-cast, stainless steel (304) cap and dust shutter.  
Cam and clip: Steel, zinc plated.

### SQUARE LATCH FOR CLIP-IN MOUNTING

P/N	Description	P/N	Description
72350001-1	Keyed alike	72350001-2	Keyed to differ