

Opening angle

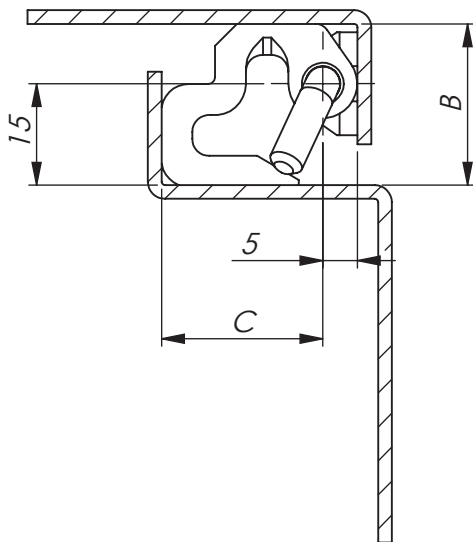

Universal LH / RH



CONCEALED HINGE - 120° OPENING ANGLE

Concealed hinge for internal mounting.
Universal left and right mounting. Opening angle 120°. Frame part mounted with screws, door part provided with warts for press welding.

E-clip to be ordered separately.

MATERIAL:

Frame part: Zinc die-cast, zinc plated.
Door part and pin: Stainless steel (304).
E-clip: Acid-proof stainless steel (316).

CONCEALED HINGE - 120° OPENING ANGLE				
P/N	Description	A	B	C
311115	Concealed hinge	65	25	24
311116	Concealed hinge	80	24	29
069093	E-clip	-	-	-

Specifications subject to change without notice