

Opening angle



Universal LH / RH



Adjustable 5,5 mm

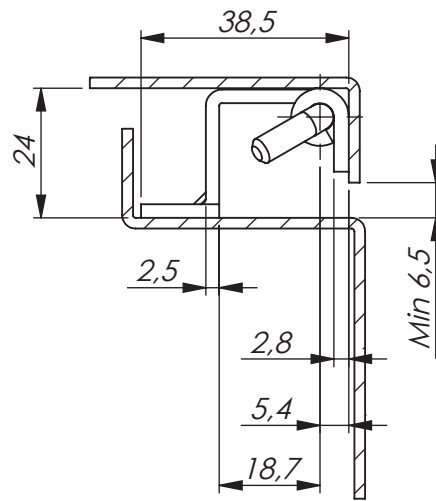

Specifications subject to change without notice

STAINLESS ADJUSTABLE CONCEALED HINGE - 120° OPENING ANGLE

Stainless adjustable adjustable concealed hinge for surface mounted doors. Opening angle 120°. Universal left and right mounting. For weld-on and screw mounting. The hinge can be adjusted 5,5 mm vertically. Supplied with E-clip.

Steel version: Page 3-060.

MATERIAL:

Stainless steel (304).

STAINLESS ADJUSTABLE CONCEALED HINGE - 120° OPENING ANGLE

P/N	Material	Door part	Frame part
313010	SS (304)	Weld-On	Screw