

Hinge

Removable pin in nickel plated steel

A	B	C	D	S	part number	material	finish	weight
46	99	21.5	5	3.5	72-7-3328	zinc die-cast	chrome plated	84g

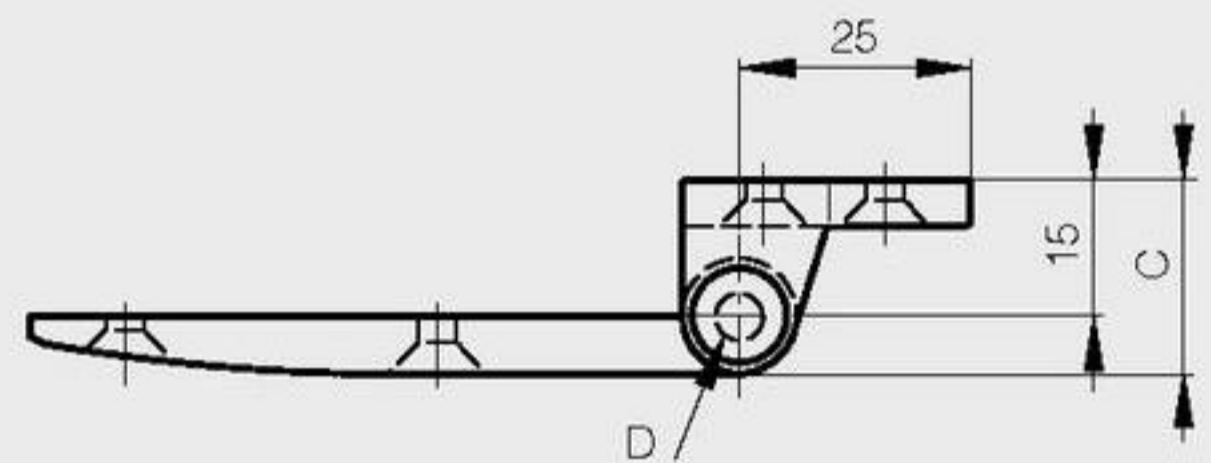
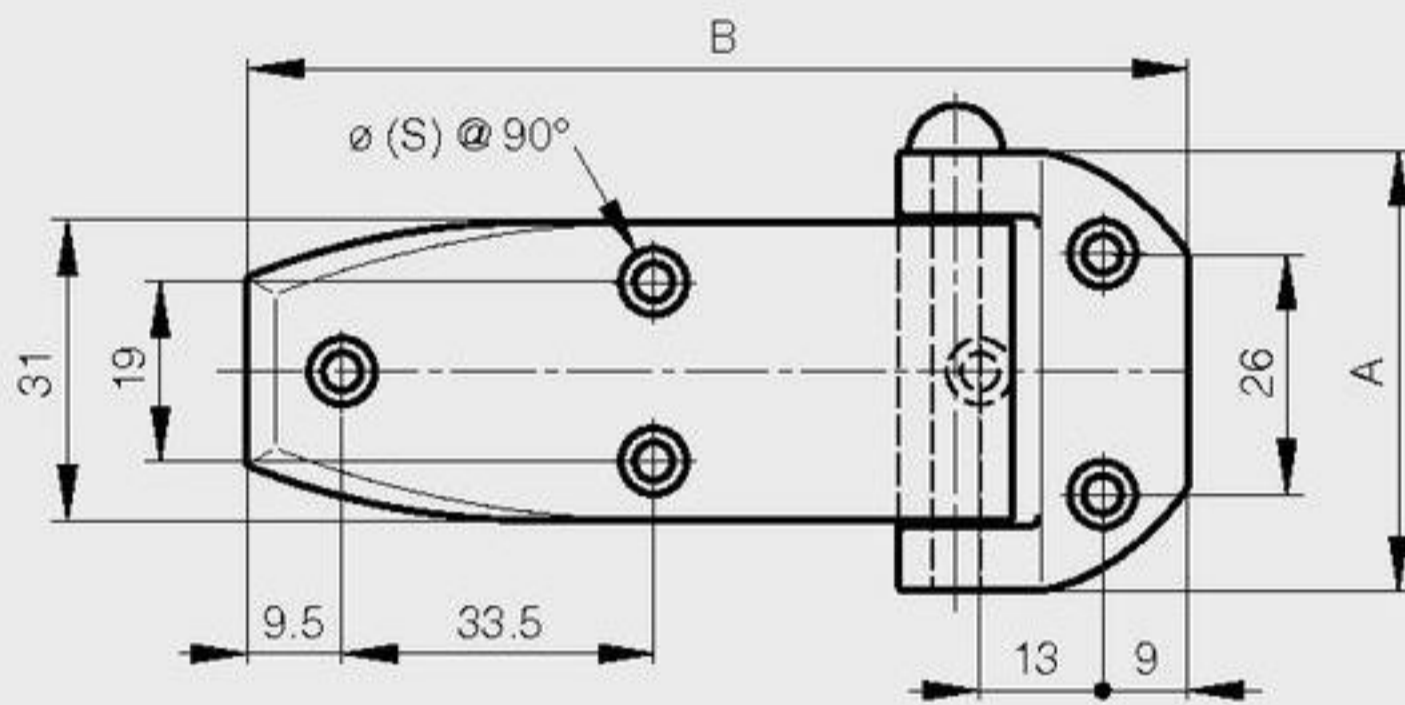

Tube hinge

A	B	C	note	part number	material	finish	weight
144	16.9	49	no stop	70-1-3526	steel	zinc plated	100g

