

Hinges

Removable pin in nickel plated steel

A	B	D	S	part number	material	finish	weight
62	76.6	4.9	3.5	51-1-3300	alu	polished	25g
62	76.6	4.9	3.5	53-1-3300	brass	nickel plated	50g

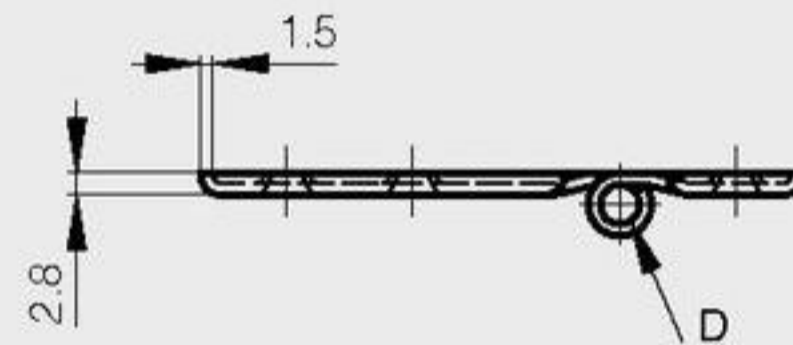
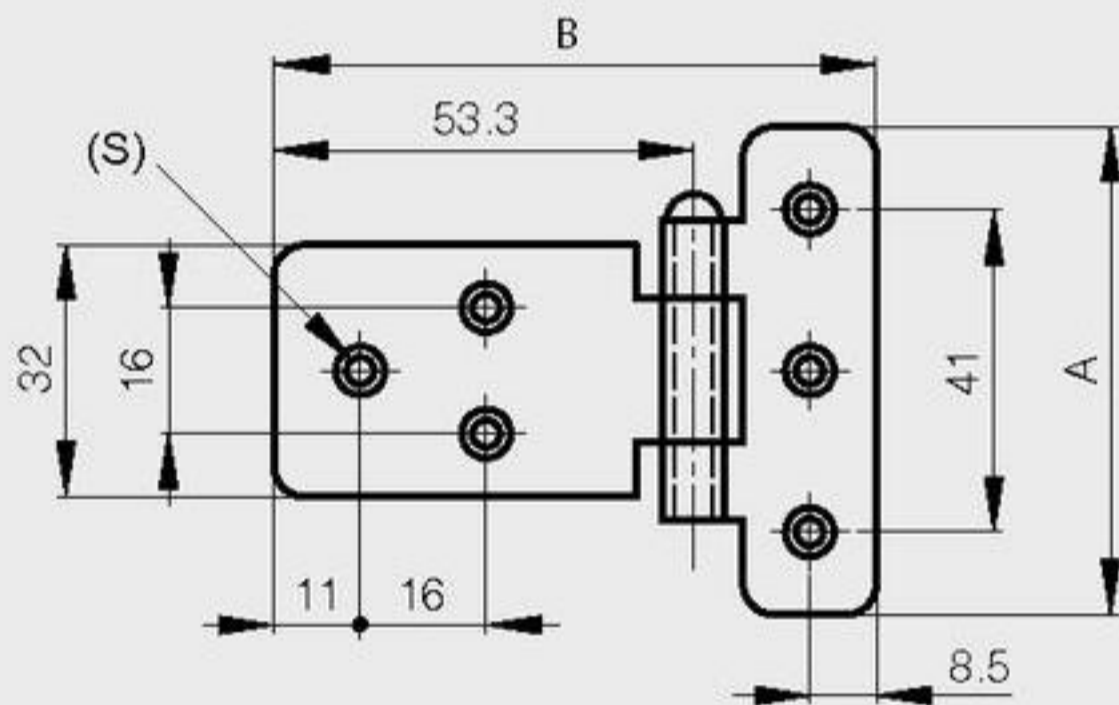

Removable pin in nickel plated steel

A	B	C	D	S	part number	material	finish	weight
46	99	6	5	3.5	72-7-3327	zinc die-cast	chrome plated	80g

