

Lift-off hinges for adjacent door

A full product data sheet is available on our website.

A	B	C	D	note	part number	material	finish	weight
50	35.7	4	6.4	type 1 symmetric not shown	72-7-4174	zinc die-cast	black	230g
50	35.7	4	6.4	type 2 as shown below	72-7-4175	zinc die-cast	black	230g

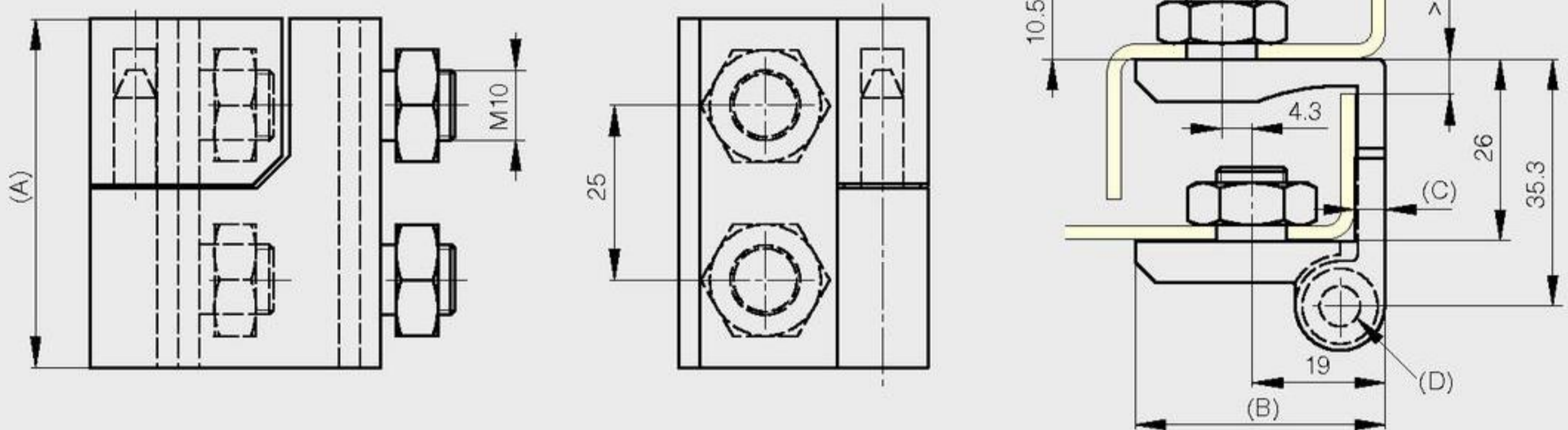

Glass door hinge

Hinge delivered in separate parts including:

- Brass hinge 25 x (30 + 18.5)
- Brass plate 25 x 30
- Countersunk screw M6 and connector in brass
- 2 countersunk screws M4 x 10 in steel
- 2 brown steel washers
- 2 M4 steel bolts

Glass thickness: 5mm max



A	B	D	material pin	part number	material	finish	weight
25	48.5	4	stainless steel	72-1-3753	brass	black zinc plated	53g

