

Hinges for marine applications

Riveted pin

A	B	C	D	S	part number	material	finish	weight
36.5	36.5	2	5	6	52-1-3945	316 stainless steel	polished	32g

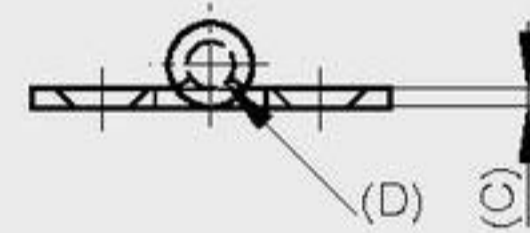
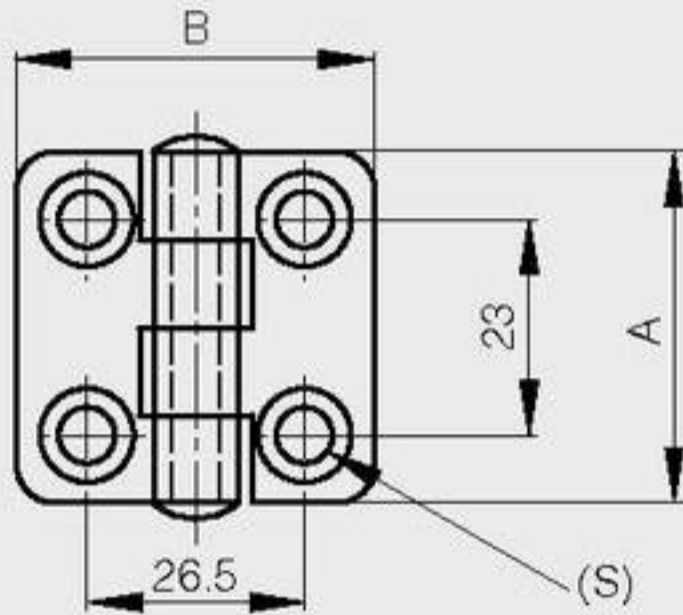

Riveted pin

A	B	C	D	S	part number	material	finish	weight
36.5	56.5	2	5	6	52-1-3947	316 stainless steel	polished	40g

