

Hinges

A	B	C	D	S	part number	material	finish	weight
65	70	2	4	6.7	50-1-3312	steel	zinc plated	81g

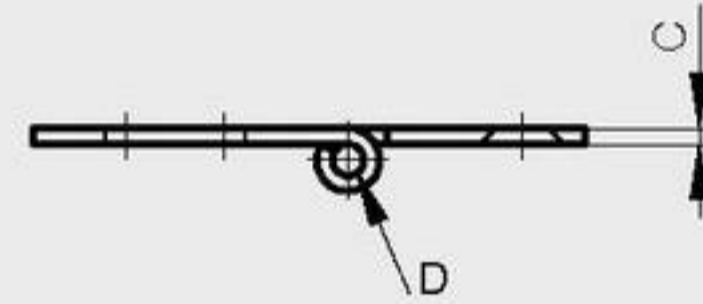
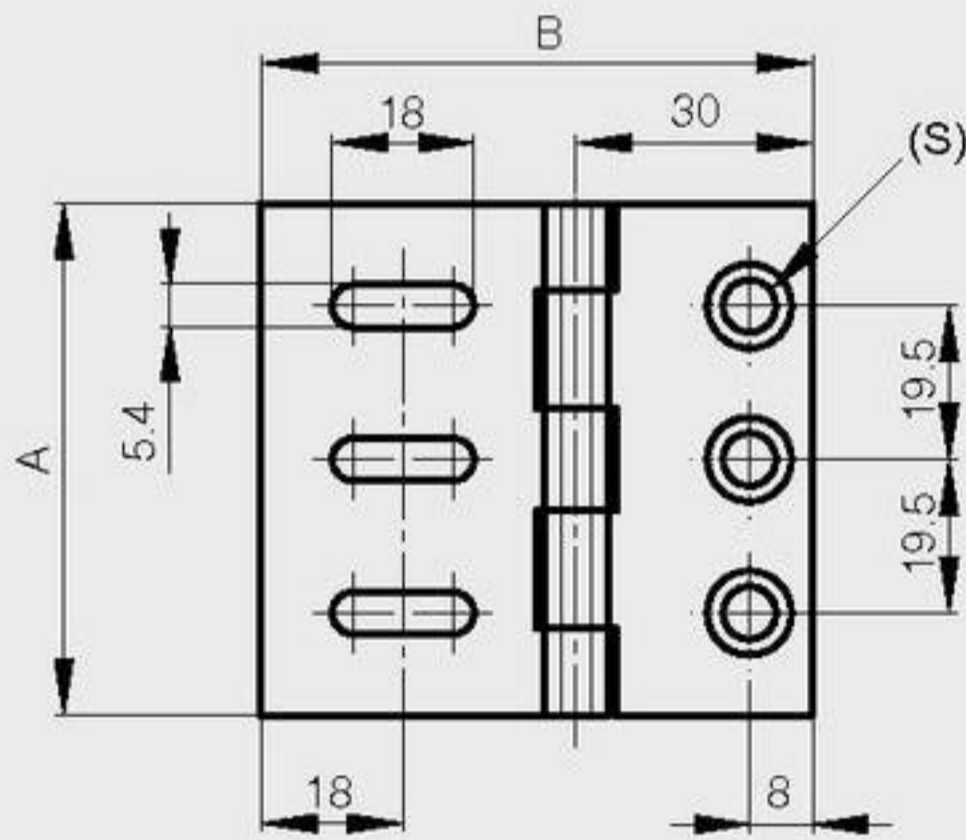

Removable pin

A	B	C	D	part number	material	finish	weight
60	94.5	1.5	4	52-1-3877	304 stainless steel	gloss	50g

