

**Sealed magnetic catch**

A	B	C	D	force	part number	material	finish	weight
50	21	13	40	3kg	16-7-4081	plastic	white	21g
50	21	13	40	3kg	16-7-4206	plastic	black	21g

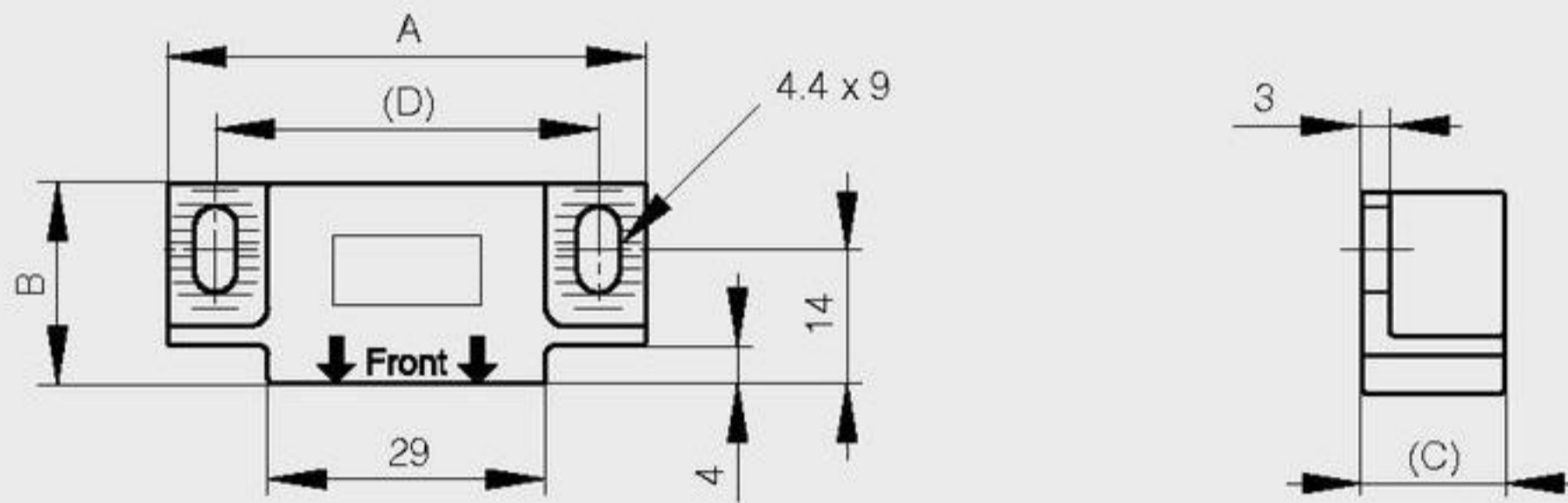

**Counterplate for sealed magnetic catch 16-7-4081 and 16-7-4206**

A	B	C	D	part number	material	finish	weight
49	15	2	40	16-7-4082	316 stainless steel	raw	10g

