

Ultra thin compact magnetic catch

Suitable for temperatures below 80°C
 To avoid breakage, counterplate should not connect with magnet.
 Screw heads should not protrude above the base plate.

A	B	force	part number	material	finish	weight
35	12	2.7kg	16-7-4033	steel	nickel plated	4g

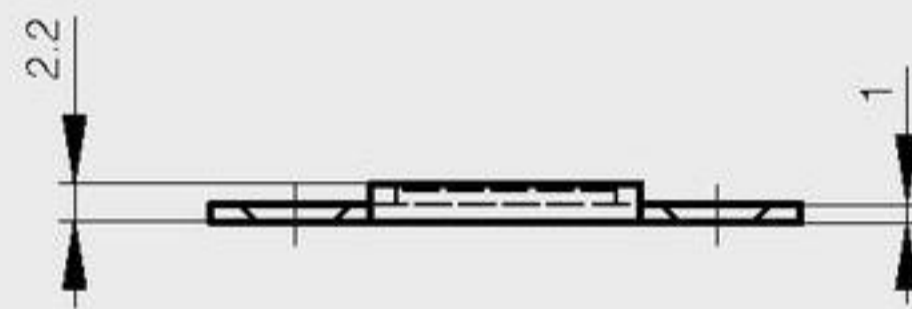
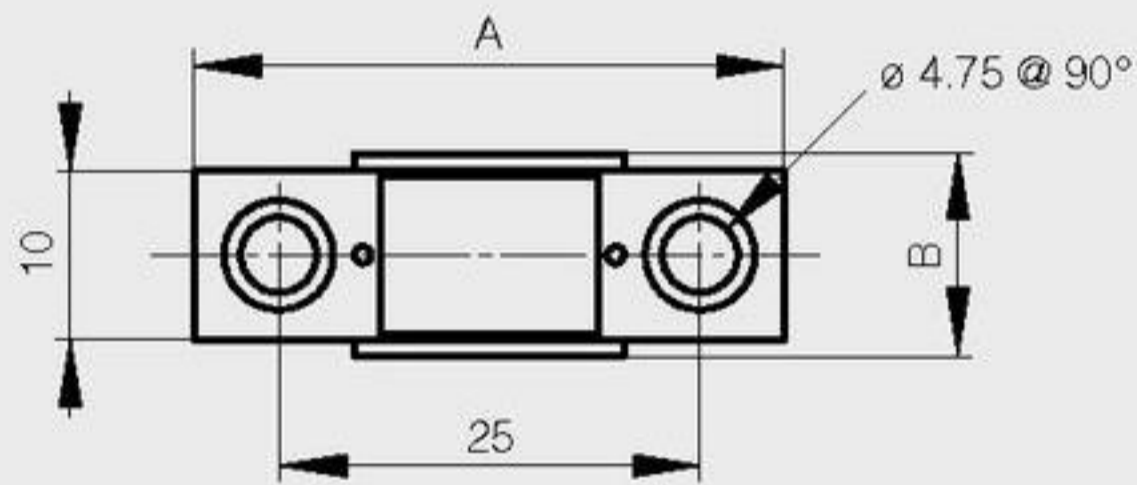

Compact magnetic catch

new!

Suitable for temperatures below 80°C
 To avoid breakage, counterplate should not connect with magnet.
 Screw heads should not protrude above the base plate.

A	B	force	part number	material	finish	weight
41	16.5	4kg	16-7-4207	steel	nickel plated	12g

