

Screw-on sealed magnetic catches with counterplate

A	B	C	force	part number	material	finish	weight
54	16	15	4kg	16-7-3483	zinc die-cast	nickel plated	49g

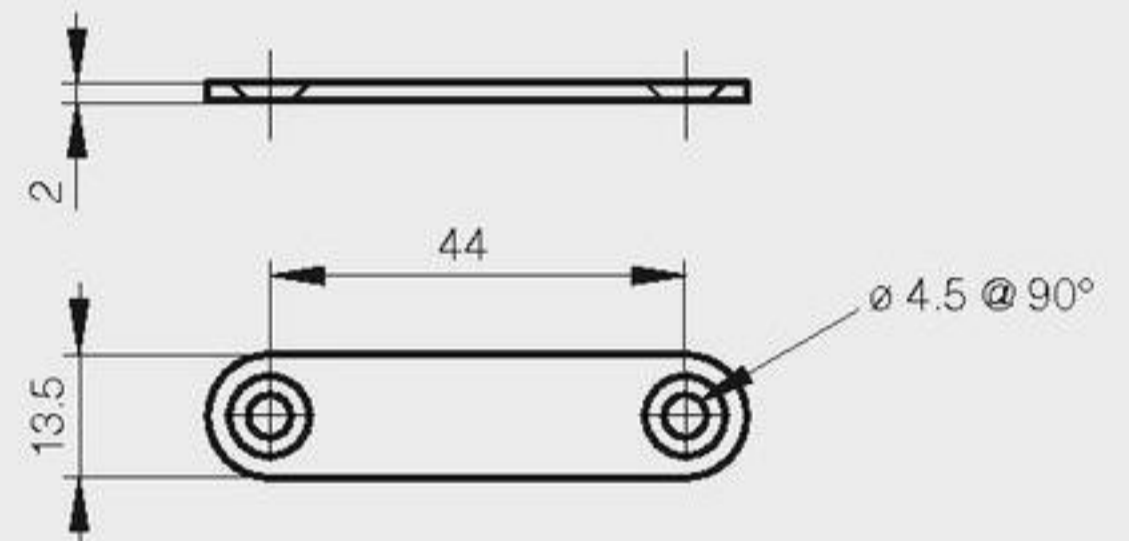
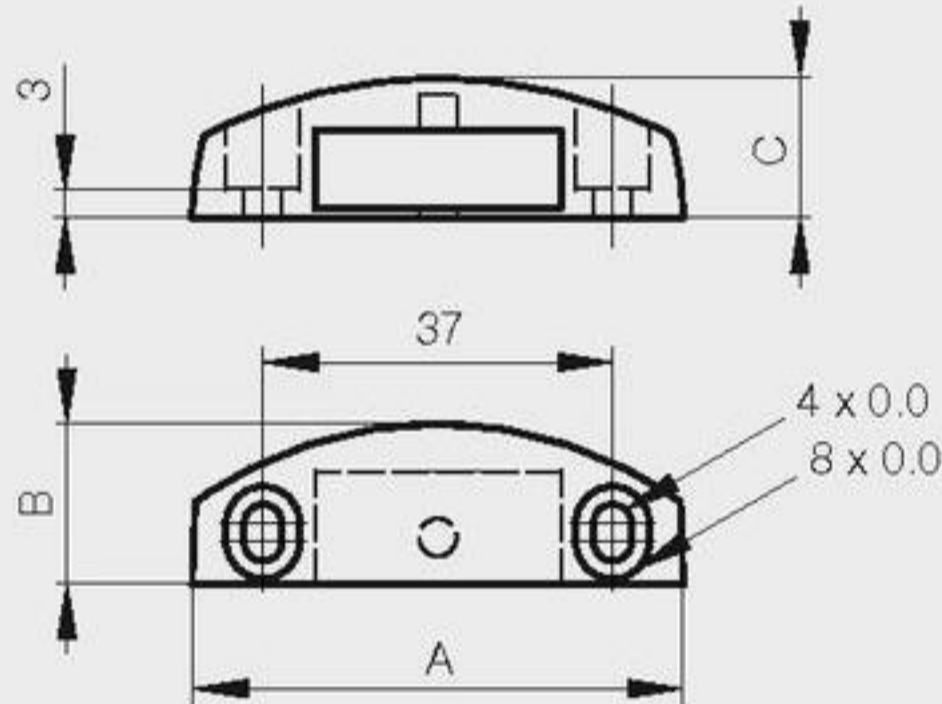

430 stainless steel magnet

A	B	C	D	E	F	G	H	force	part number	material	finish	weight
86	13	15	77	12	57	70	9.2	4.8kg	16-7-3861	plastic	white	100g
105.3	16	18	94	14	65	79	11.4	5.6kg	16-7-3862	plastic	white	100g

