

Screw-on magnetic catches without counterplate

A	B	C	D	force	part number	material	finish	weight
48.5	16.5	13	39	4kg	16-7-3372	plastic	white	18g
53.5	16.5	13.5	39	4kg	16-7-3388	plastic	white	24g

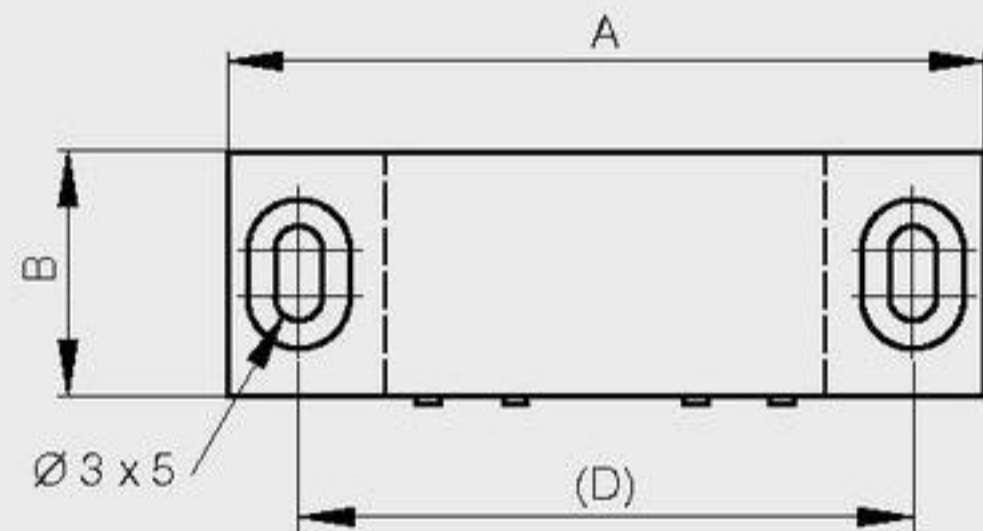
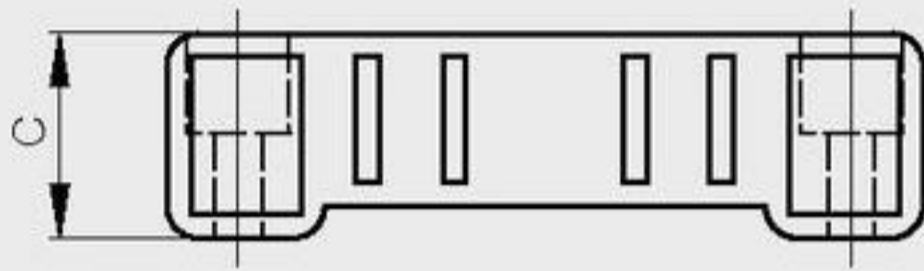

Counterplates for magnetic catches 16-7-3372 and 16-7-3388

A	B	C	D	note	part number	material	finish	weight
50.5	14	4.5	40	for part number 16-7-3372	16-7-3648	plastic	white	6g
58	15	4.5	48	for part number 16-7-3388	16-7-3649	plastic	white	7.5g

