

Screw-on magnetic catches with counterplate

Forces valid with the related counterplate.

A	B	C	C1	C2	D	E	F	G	S1	S2	force	part number	material	finish	weight
56	12	15.2	5	5	40	15.5	57	42	3.2x5	7	3kg	16-7-3486	plastic	white	23.5g
58	12	15.2	5	5	42	15.5	57	42	3.2x6	8.1	4kg	16-7-3487	plastic	white	31g
62.1	12.6	15.2	6	5.5	45	16.4	62	44.7	3.2x6	8.1	6kg	16-7-3488	plastic	white	41g

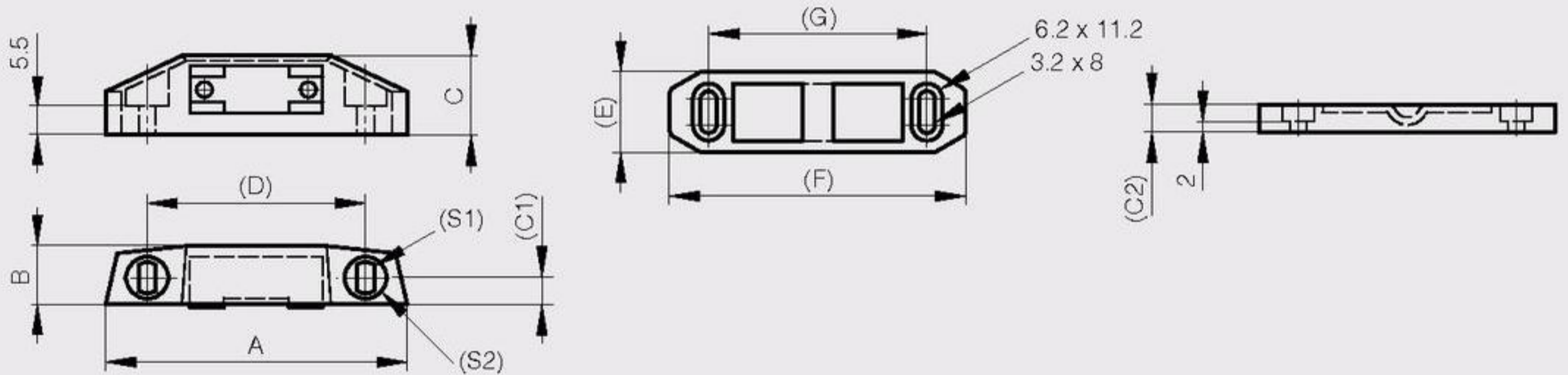

Screw-on magnetic catches with counterplate

A	B	C	force	note	part number	material	finish	weight
86	16.4	15.6	8kg	temperature up to 80°C	16-7-3391	zinc die-cast	nickel plated	112g
86	16.4	15.6	8kg	temperature up to 300°C	16-7-3611	zinc die-cast	nickel plated	112g

