

Padlockable toggle latch

This latch is used with strike part numbers 16-7-3414 and 16-7-3418 (see below).

A	B	C	part number	material	finish	weight
49	22.5	19	16-7-3396	steel	raw	25g
49	22.5	19	16-7-3394	steel	zinc plated	25g

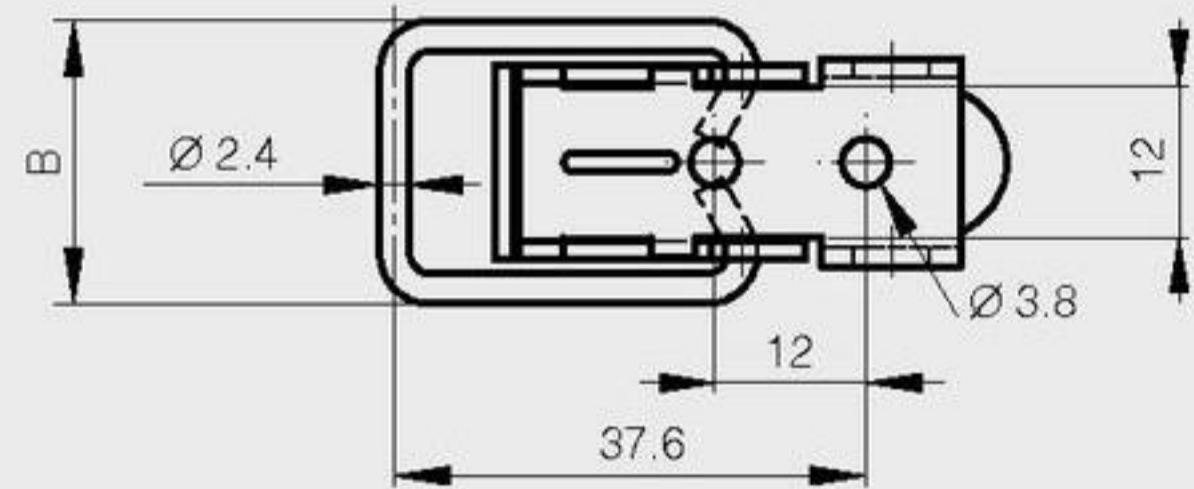
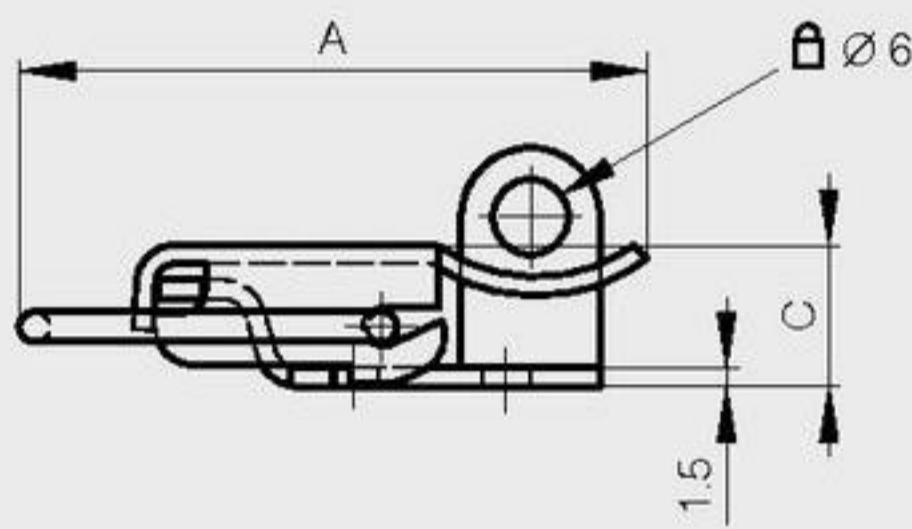

Strikes for part numbers 16-7-3394 and 16-7-3396

A	B	C	D	E	note	part number	material	finish	weight
12.8	24	1.5			undrilled	16-7-3418	steel	raw	3.5g
12.8	24	1.5	14	5	drilled	16-7-3414	steel	zinc plated	3.5g

