

**Paddle latches**

A	B	note	part number	material	finish	weight
68.5	84	with key	16-1-4087	steel	chrome plated	184g
68.5	84	with key	16-1-4106	steel	zinc plated	184g
68.5	84	with key	16-1-4108	304 stainless steel	raw	184g
68.5	84	without key	16-1-4105	steel	zinc plated	184g
68.5	84	without key	16-1-4217	steel	black	184g
68.5	84	without key	16-1-4107	304 stainless steel	raw	184g

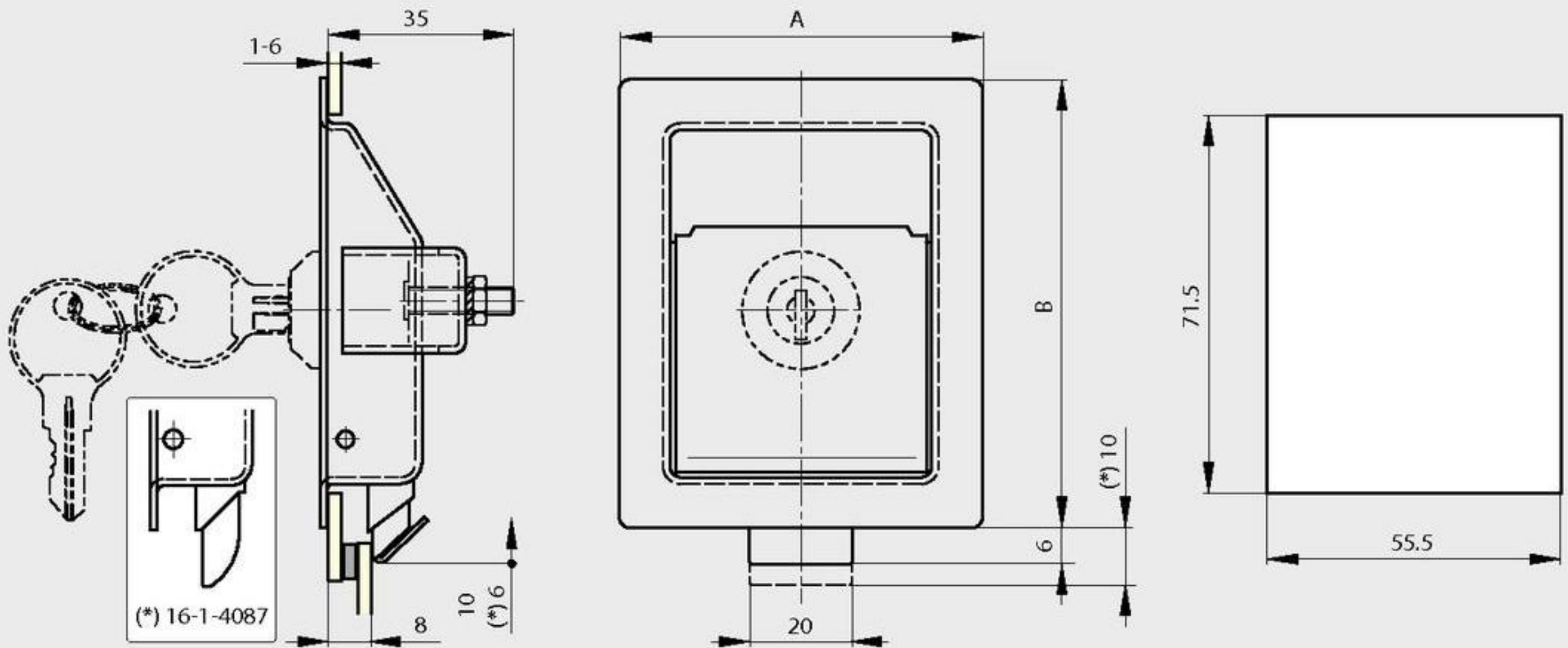

A	B	note	part number	material	finish	weight
41	92	with key	16-1-4088	304 stainless steel	brushed	162g

