

6-1330SL Revolving Pull Handle SNAP-LINE



This Handle is suitable for the computer industry, 19" technology, insertions and equipments and other applications.

- Designed for vertical or horizontal uses.
- The corrugation shows the fitting position.
- A soft push on the fluted position makes the handle revolving into the final, open position.
- A soft push makes the swiveled out handle fall back. For closing to a fully flush surface the end of the handle has to be pushed to the housing.
- Installation by a simple push into appropriate cutout.

Material:

- **Handle and Dish:**
PA, black
- **Pin:**
steel, zinc plated
- **Snap wedges:**
sintered steel

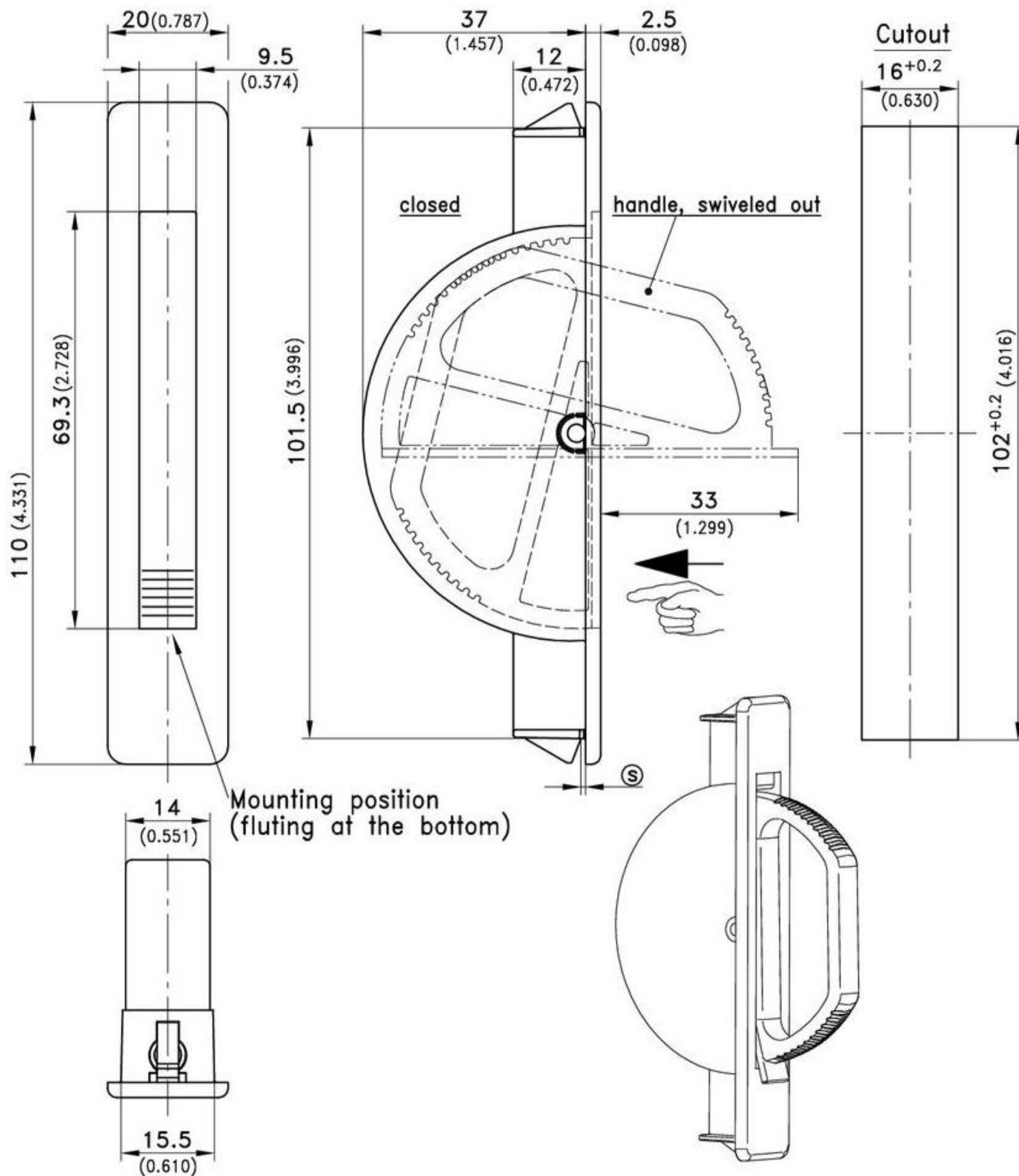

	clamping range ©	Part No.
Revolving Handle	0,8 - 1,5	413-9005.00-00015
	1,3 - 2,0	413-9005.00-00020

Other © - dimension on request!