

6-080SL Tool for uninstallation SNAP-LINE

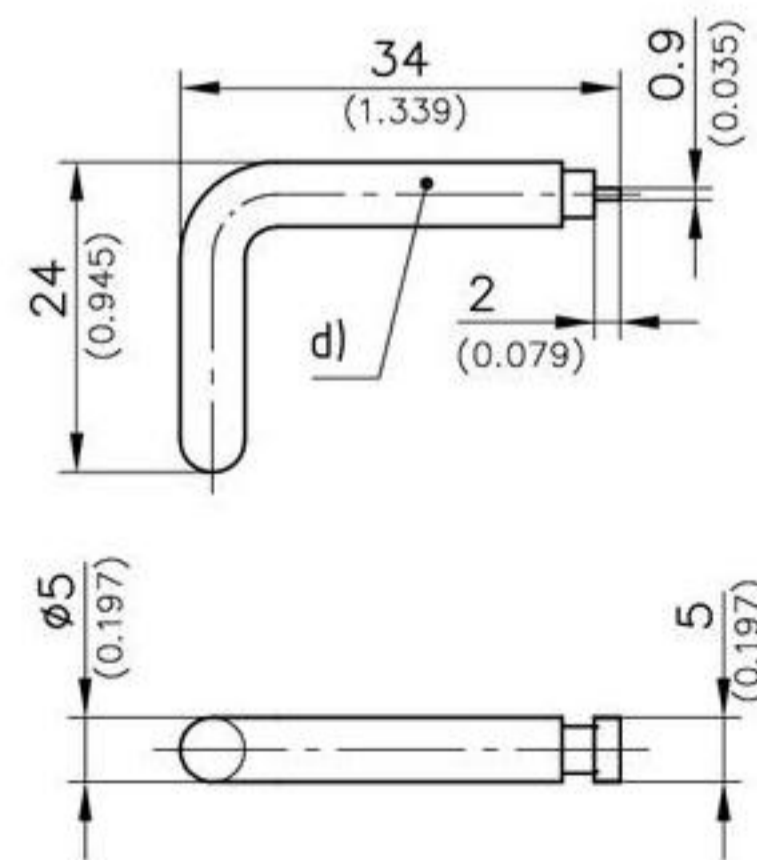

- a) Tool for uninstallation for all SNAP-Cutouts 30x8, 30x10, 30x14 and 30x15 and 25mm(0.984) length.
- b) and d) Tool for uninstallation for SNAP-Joiner.
- c) Tool for uninstallation for all SNAP-Cutouts with 14mm(0.551) and 15mm(0.591) width.

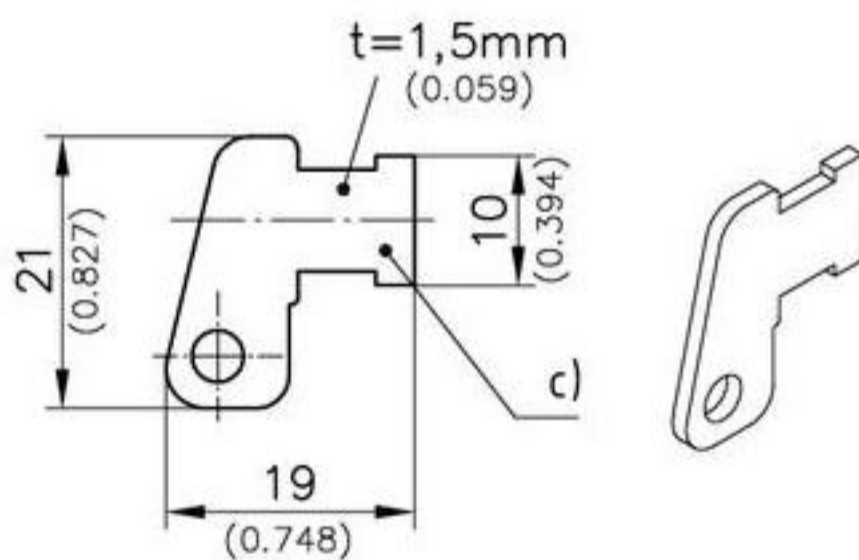
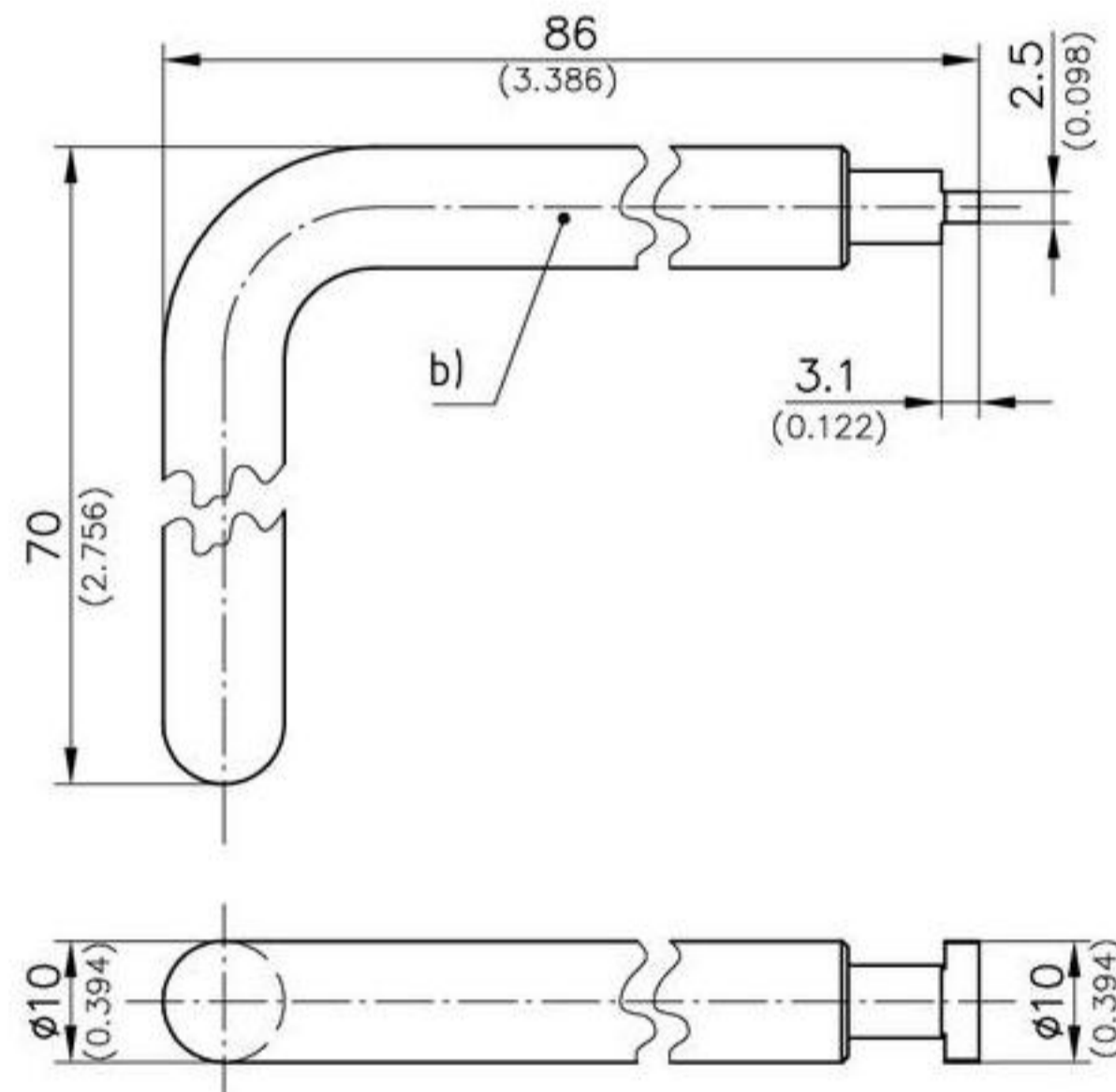
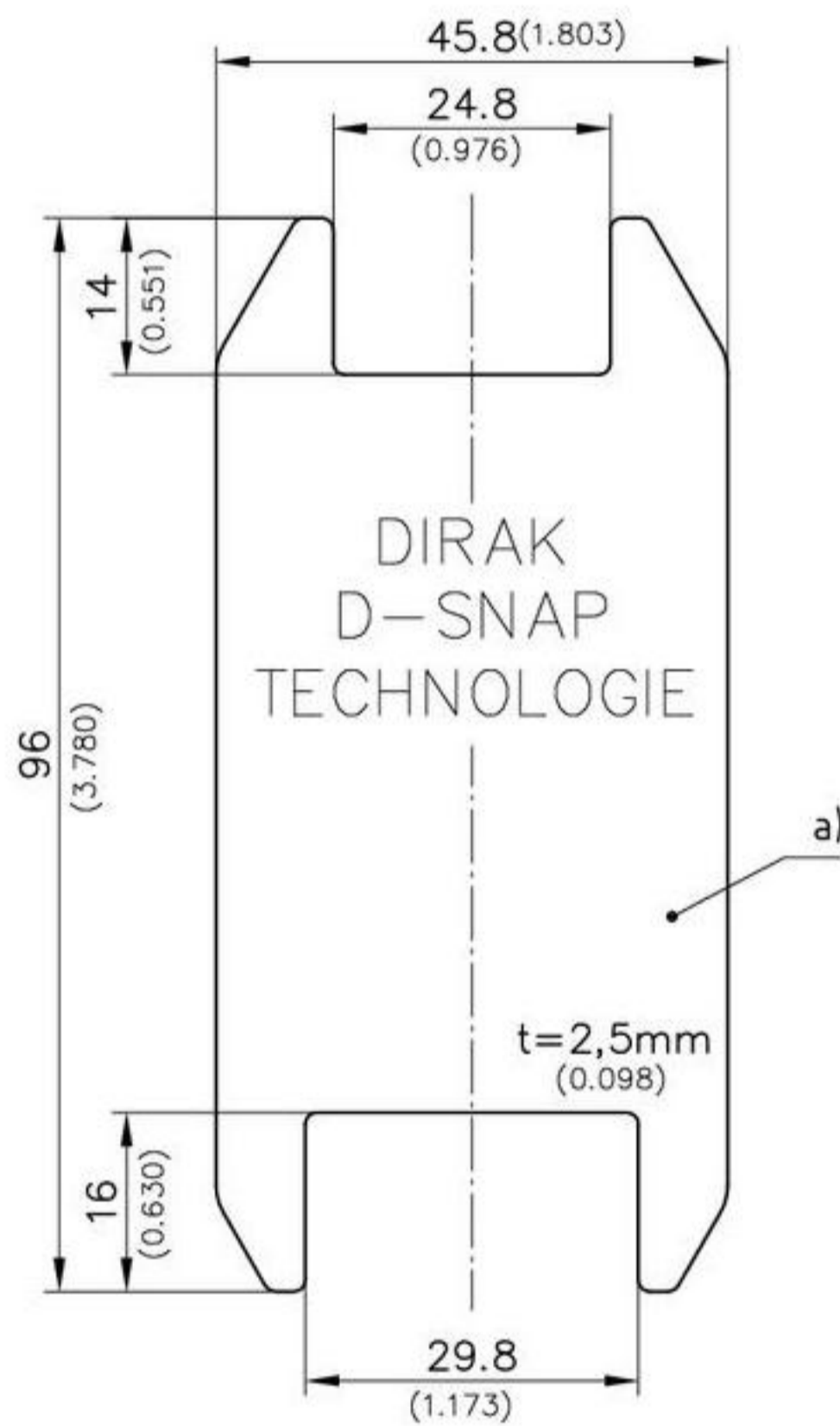

	Material	Part No.
a) Tool for uninstallation	stainless steel	292-0306.80-02530
b) Tool for uninstallation	steel, chrome plated	292-0311.15-00000
c) Tool for uninstallation	steel, zinc plated	292-0301.15-00000
d) Tool for uninstallation	brass	292-0302.70-00000