

# 1-060 Snap/Push-Lock



Snap/Push lock with slam function, nut or clip fixing.

- Released by pushing.
- Lager lockable version see page 05.7 or 05.8.

**Material:**

- Version A:
- Snap-Lock:** zinc die, chrome plated
  - a) **Fingerpull:** PA, black
  - Version B:
  - Snap-Lock:** zinc die, chrome plated

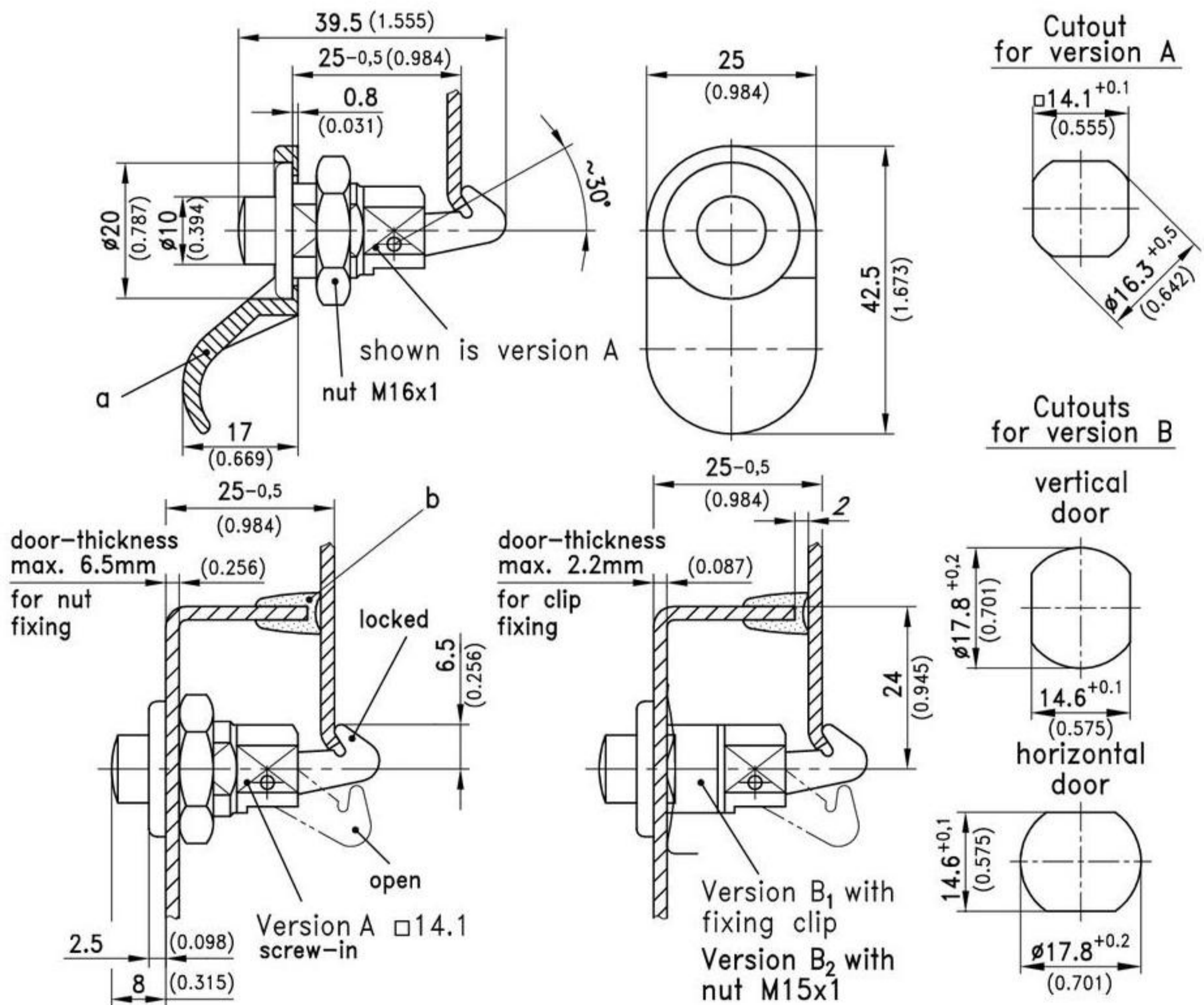

Snap/Push lock Version A	Part No.	see page
A for $\square$ 14,1mm / 0.555	252-9001	
Please order separately:		
a) Finger pull (only for version A)	220-1301	
Snap/Push lock Version B		
B1 with fixing clip	252-9003	
B2 with nut M15x1	252-9004	
b) i.e. Rectangular Profiles	209-0301	07.9