

# 1-057 Quarter-Turn Pr14.1 L13.5

Clip-in



Clip-in Quarter-Turn, RH or LH application.

- The Quarter-Turn consists of two basic components which can be combined to suit your application.
- A pre-assembled Quarter-Turn can be installed in the cutout.
- **Explanation of the clip-in feature:**
- The 2 clip-in noses (refer to drawing) must be able to move into the direction of the insert.
- This is only possible in the assembled delivery condition (OPEN) as supplied by DIRAK.
- In the position "closed" the 2 clip-in noses can NOT move inwards, resulting in secure and strong fixation in the cutout.

**Material:**

- a)
  - **Housing:** PA, black
  - **Insert:** PA, black
  - **Hexagon head screw:** stainless steel
- b)
  - **Cam:** steel, zinc plated

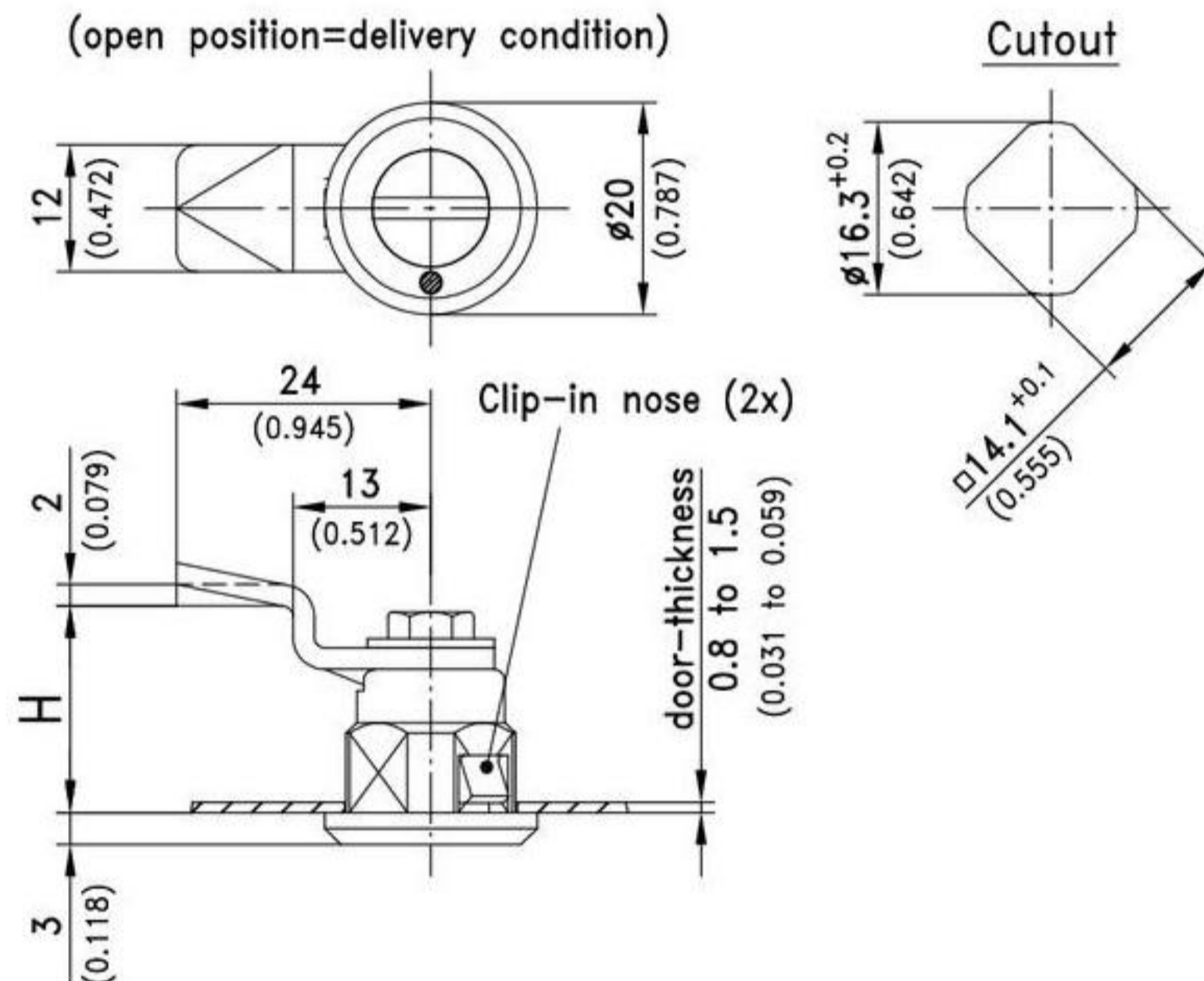

installation instruction for pre-assembled quarter-turn

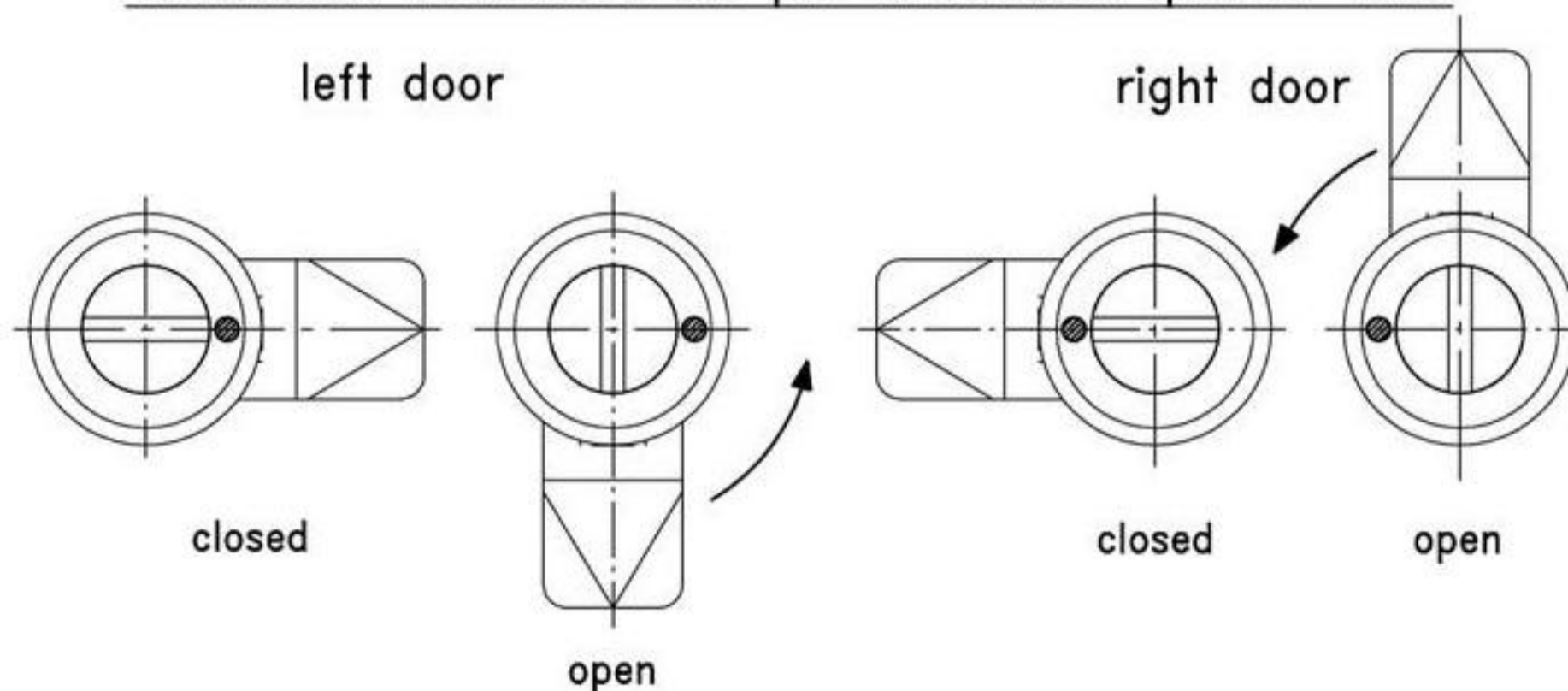

a) Housing with insert Slotted 2x4mm deep	Part No. 220-9701	see page
b) Cam H in mm		
7,5	220-0503	
13,5	220-0501	
19,5	220-0502	
Special cams		02.19
c) Assembling (always in open condition)	220-0008	