

1-451 Redirection

for Explosion-Tight Doors



Redirection for explosion tight door fittings see page 02.66.

- Redirection of the rod with eye from horizontal to vertical or from vertical to horizontal.
- RH and LH application.
- Suitable for round rods $\varnothing 8\text{mm}$.
- Adapter and round rod see page 02.75.

Material:

- Redirection, spacer, rod pin, nut and circlip:
 steel, zinc plated

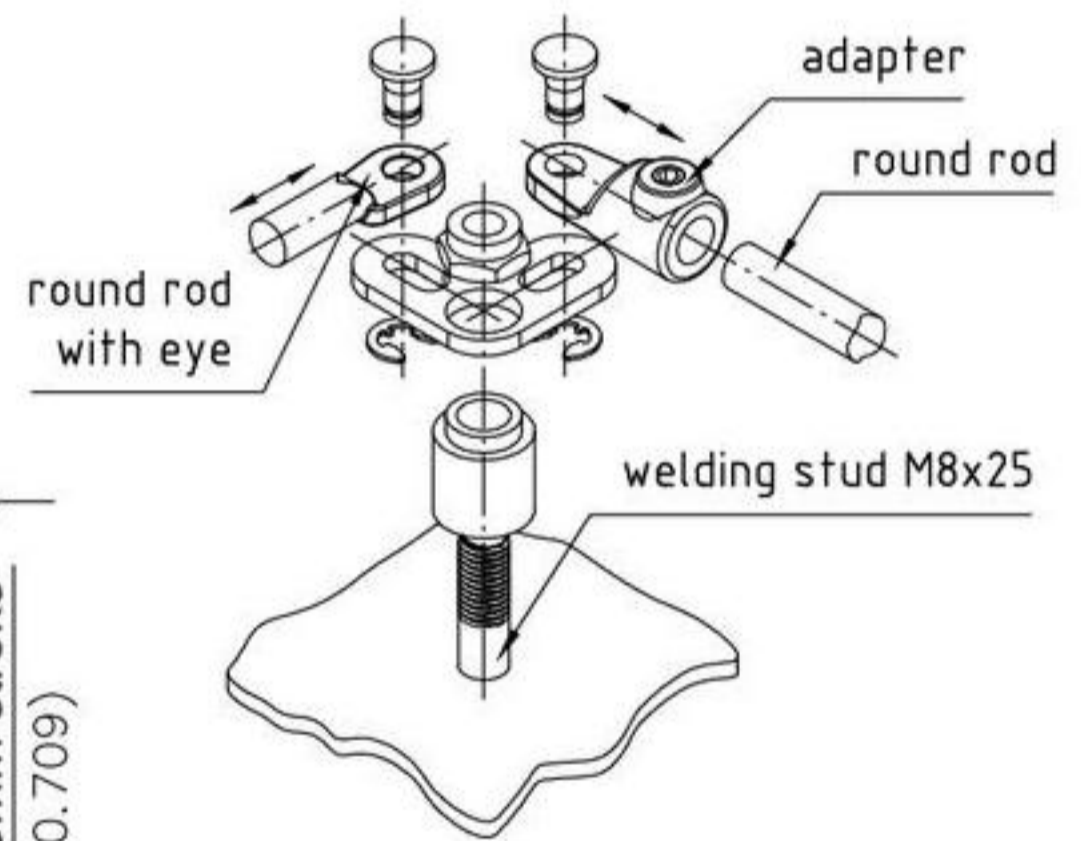
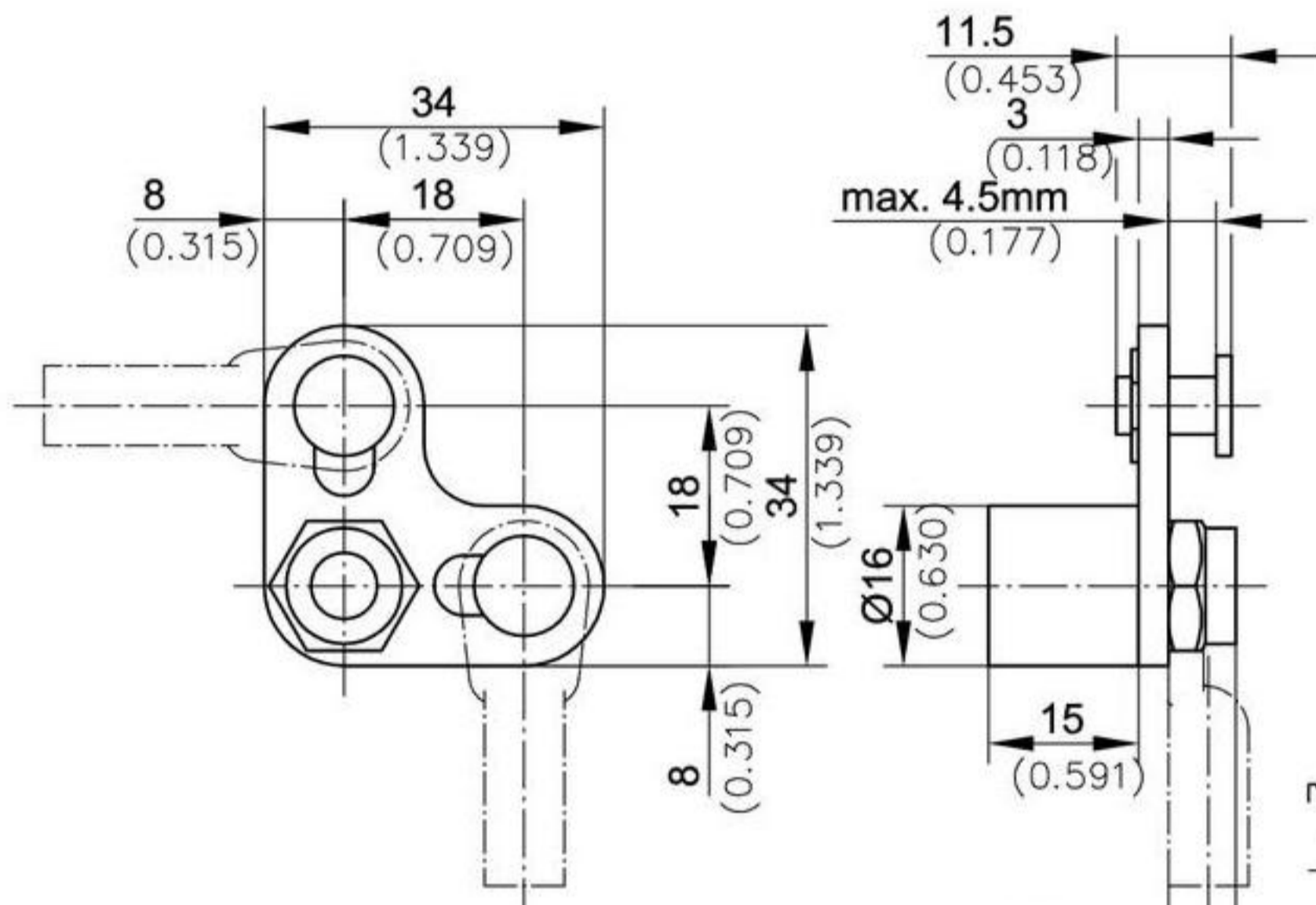

Examples of application

