

4-145 Hinge Pr05 180°

for single cabinet door, bending 16mm, for surface mounted door



180° Polyamide hinge with self-securing pin.
 • RH or LH application.

- Material:**
- **Frame part and Door part:**
PA, black
 - **Pin:**
POM, natural

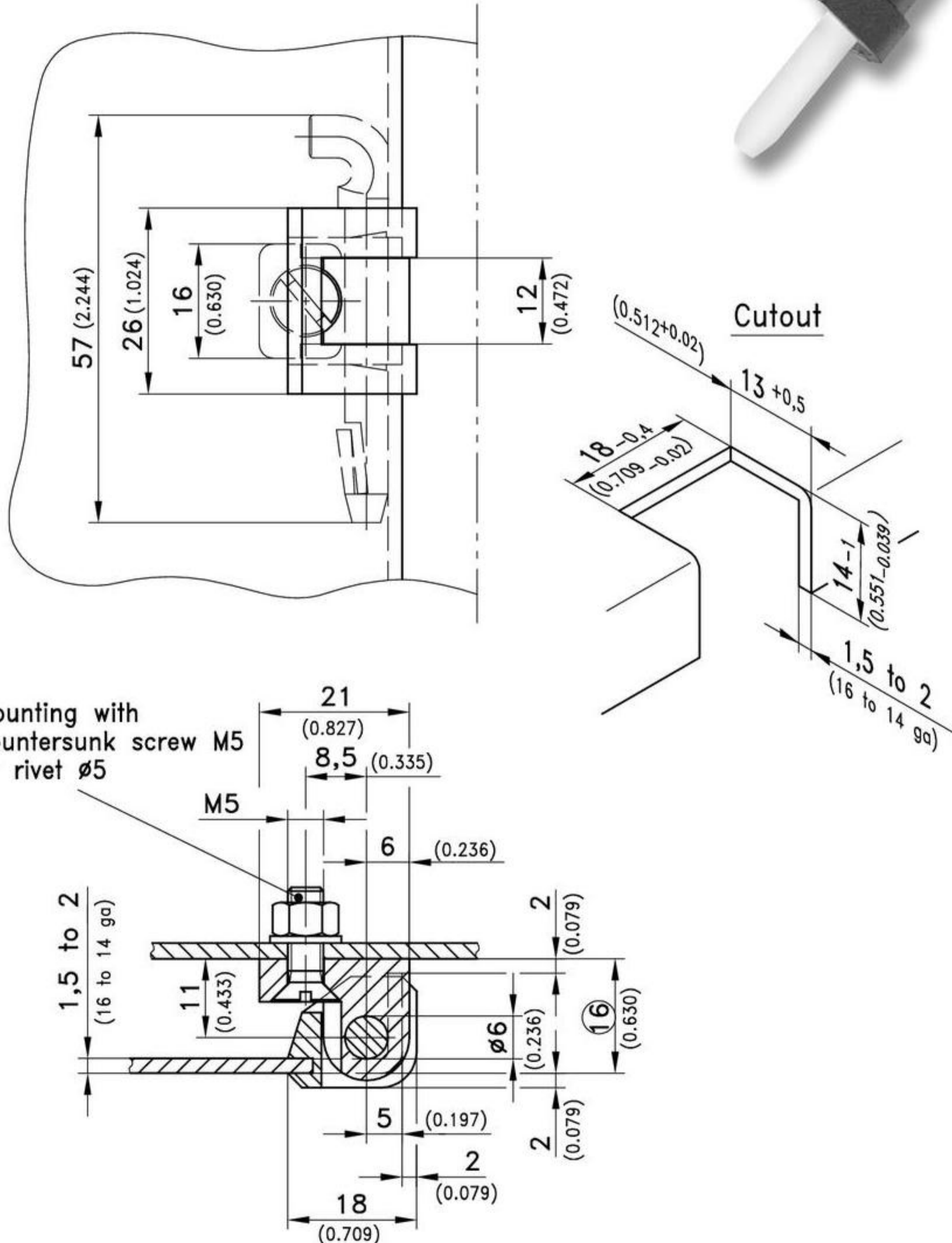

Hinge	Part No.	see page
	212-9101	
Stainless steel version		10.68
Countersunk machine screws and nuts		09.5