

2-110 Swinghandle RS 130



Flush mounted Swinghandle for sheet metal and plastic enclosures. The Swinghandle has a 90° rotation.

- RH or LH application.
- The polyamide handle is fully insulated.
- The Swinghandle can be locked with 40mm long Profile Cylinders (DIN 18252).
- Water- and dust-tight according to IP65 DIN EN 60529.
- The combination with the rod control of the 208-series is made possible by applying the lock support c).

Material:

- a), a1), a2) and a3) **see statement**
- b) and b1)
- **Rod Latch:**
zinc die/steel zinc plated
- c)
- **Lock support**
zinc die
- d) and d1)
- **Adapter:**
zinc die
- e)
- **Round rods:**
steel, zinc plated
- f)
- **Rod Guide:**
PA, black

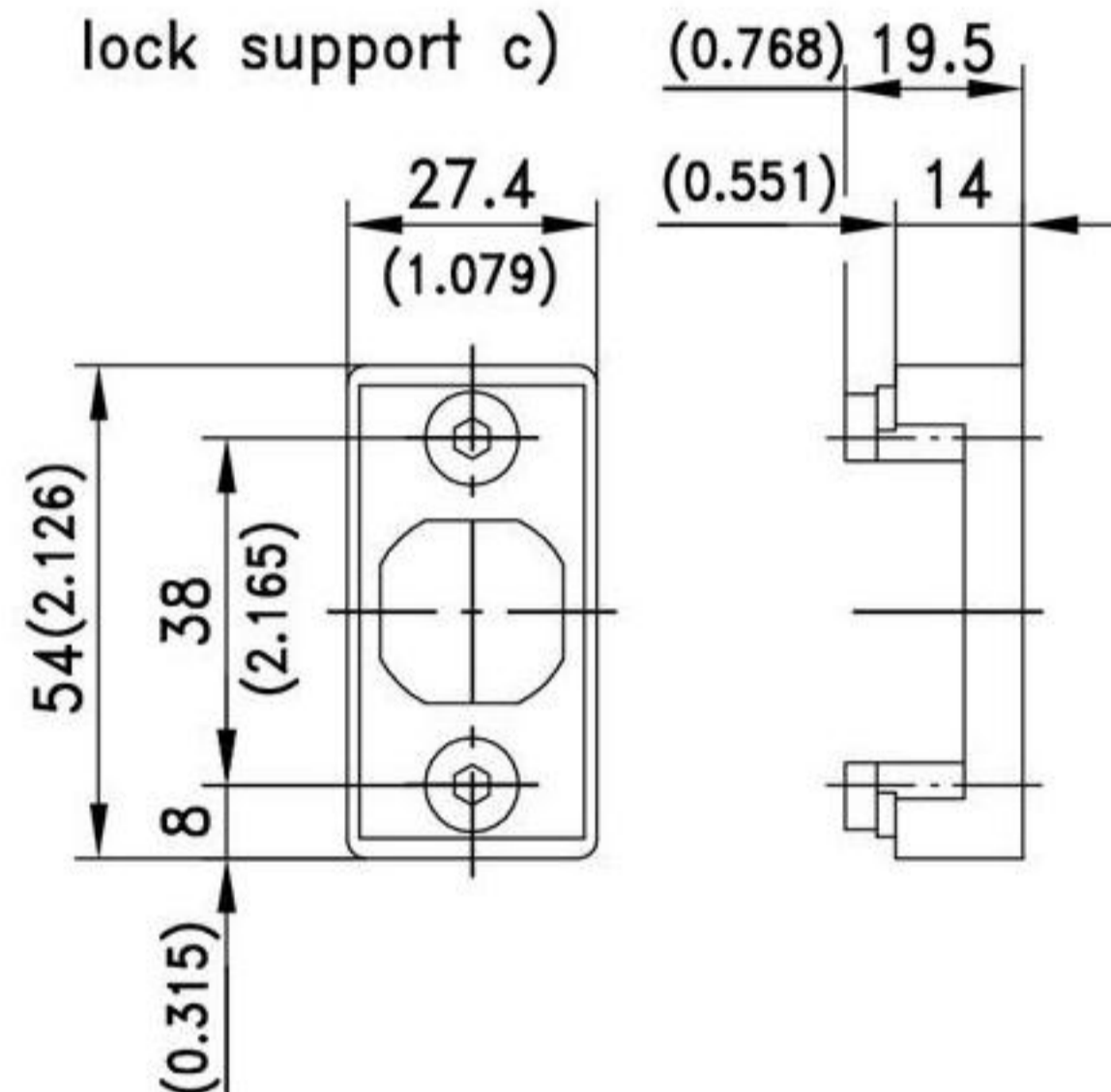

	Part No.	see page
a) Swinghandle, PA (black) for profile cylinder 40mm long	207-9023	
a1) as a), but with cylinder dustcover, sealable	207-9024	
a2) as a1), but 5mm raised for profile cylinder 45mm long	207-9030	
a3) as a2), but handle, zinc die (black), dish, PA black	207-9034	
Dish with cap $\square 46$ available from stock	207-9346	
Versions a) to a3) with cam on request		
b) Rod latch RH/LH	stroke 24mm	208-9001 04.10
b1) as b), but with	stroke 30mm	208-9008
c) Lock support		207-3501
d) Adapter	for round rod $\varnothing 8$	200-9601
d1) Adapter	for round rod $\varnothing 10$	200-9604
Optional:		
e) Round rod		02.75, 02.76, 03.30
f) Rod Guide	for bending A26	200-3602.03 02.77
g) Profile Cylinder according DIN 18252		03.34

2-110 Swinghandle RS 130

