



Buy on-line  
at the FA Parkes  
sales portal  
the quickest  
and most efficient  
way to purchase  
all your hardware  
requirements; locks  
handles, hinges  
stays, gasketing  
etc....

[www.faparkes.co.uk](http://www.faparkes.co.uk)  
your one stop shop!



**9/01830**  
Right-hand latch with  
fitted cover and  
integral inside handle

### ORDERING CODE

<b>9/01830</b>	Latch assembly, RH
<b>9/01831</b>	Latch assembly, LH
<b>9/01832</b>	Striker pin

**Note:** Above assemblies include steel cover plate, moulded trim cover and inside release handle.

### SPECIFICATION

<b>A</b> Height	80 mm
<b>B</b> Width	47 mm
<b>C</b> Depth	17 mm
<b>D</b> Location to hole	26 mm
<b>E</b> Length, handle	80 mm
<b>F</b> Location to face	9 mm
<b>G</b> Location to latch centre	19 mm
<b>H</b> Hole sizes	6 mm
<b>J</b> Hole centres	31.5 mm
<b>K</b> Hole size (Threaded)	M6
<b>L</b> Pin total length	41 mm
<b>M</b> Threaded	12 mm x 1 mm fine pitch
<b>N</b> Hexagon across flats	16 mm

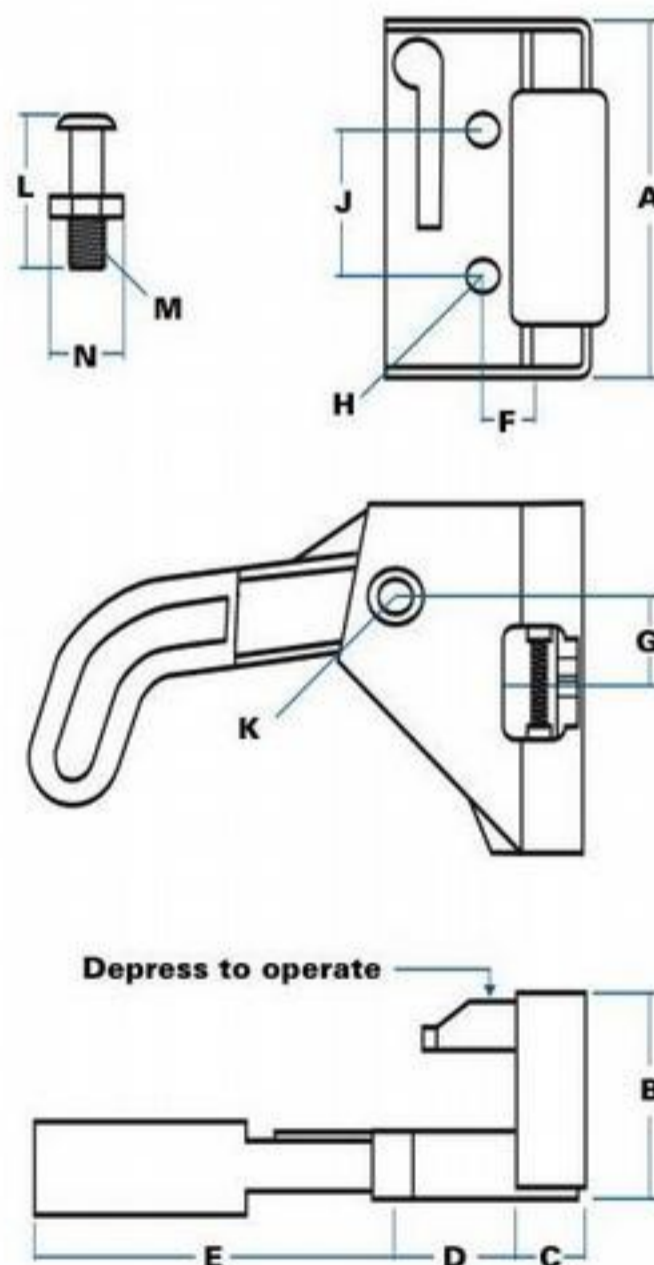

Above drawings include cover plate

View of left-hand latch from exterior, showing 'trigger' for outside release, steel cover plate and moulded trim cover.

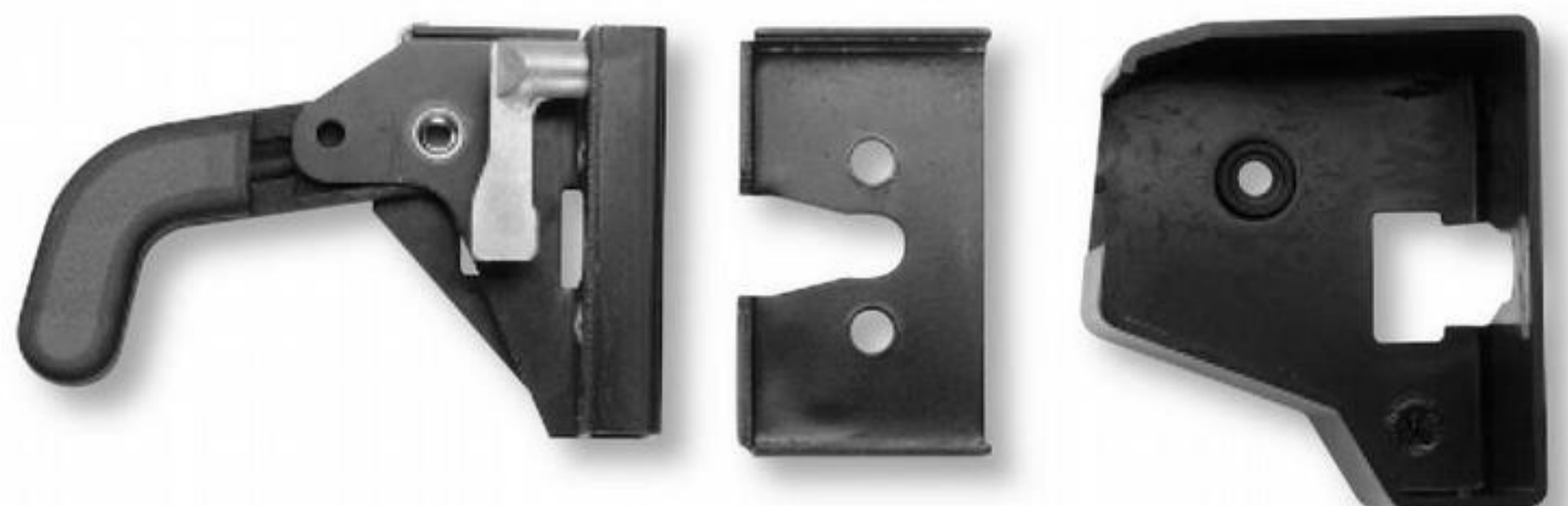

F.A. Parkes (M.B.F) Limited  
Unit 4, Acorn Court  
Butts Street, Leigh  
Lancashire WN7 3AE

Tel. 01942 681 996  
[sales@faparkes.co.uk](mailto:sales@faparkes.co.uk)