

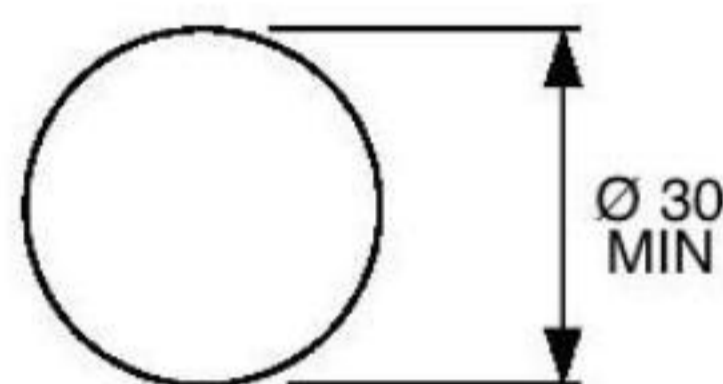

Buy on-line
at the FA Parkes
sales portal
the quickest
and most efficient
way to purchase
all your hardware
requirements; locks
handles, hinges
stays, gasketing
etc....

www.faparkes.co.uk
your one stop shop!

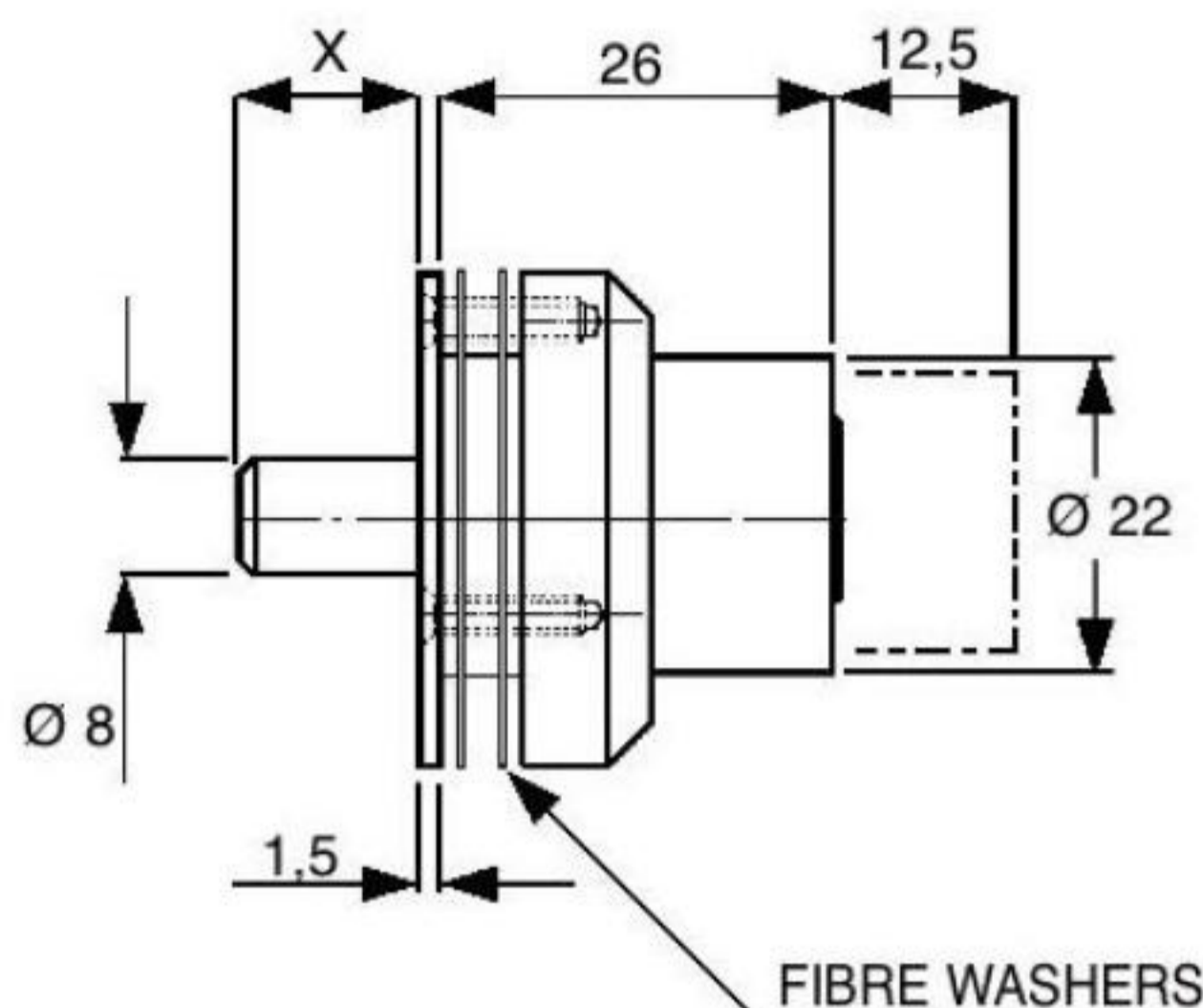
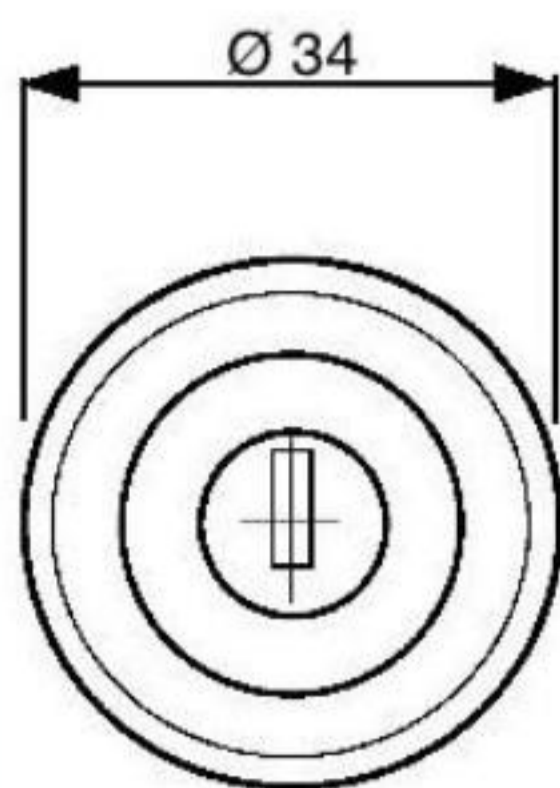

FIXING HOLE SIZE

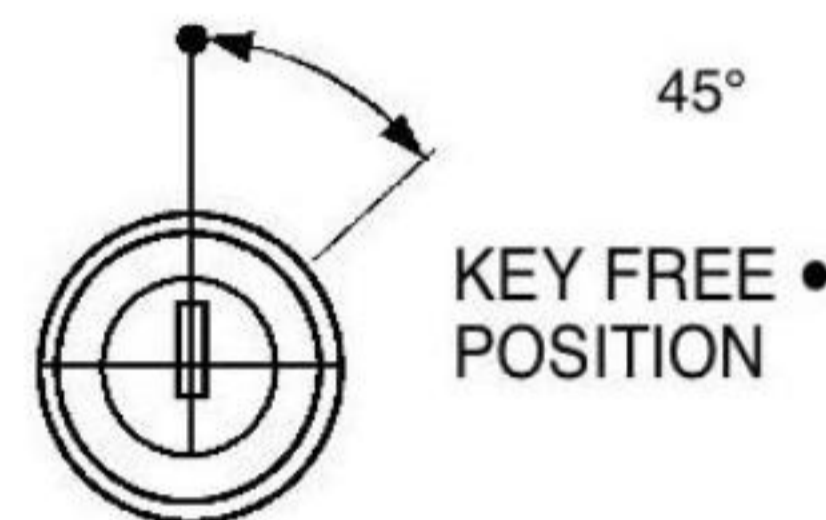

STANDARD MOVEMENT
(SPRING RETURN)

PRODUCT REFERENCE NUMBERS

KEY SERIES	COMBINATIONS	BOLT SHOOT X = 12,5mm	BOLT SHOOT X = 10,0mm
18 M	200 *	5886	(5887)

M = MASTER KEY SYSTEM: SUPPLIED TO ORDER ONLY

STANDARD MOVEMENTS: 0 (SEE DRAWING)

STANDARD FINISH: 2A = BRIGHT CHROME

REF. No. IN () INDICATES PUSH TO LOCK

THE LOCK IS SUITABLE FOR FIXING TO GLASS PANELS
3,0mm - 6,0mm THICK

* 1000 TO ORDER ONLY

F.A. Parkes (M.B.F) Limited
Unit 4, Acorn Court
Butts Street, Leigh
Lancashire WN7 3AE

Tel. 01942 681 996
sales@faparkes.co.uk