

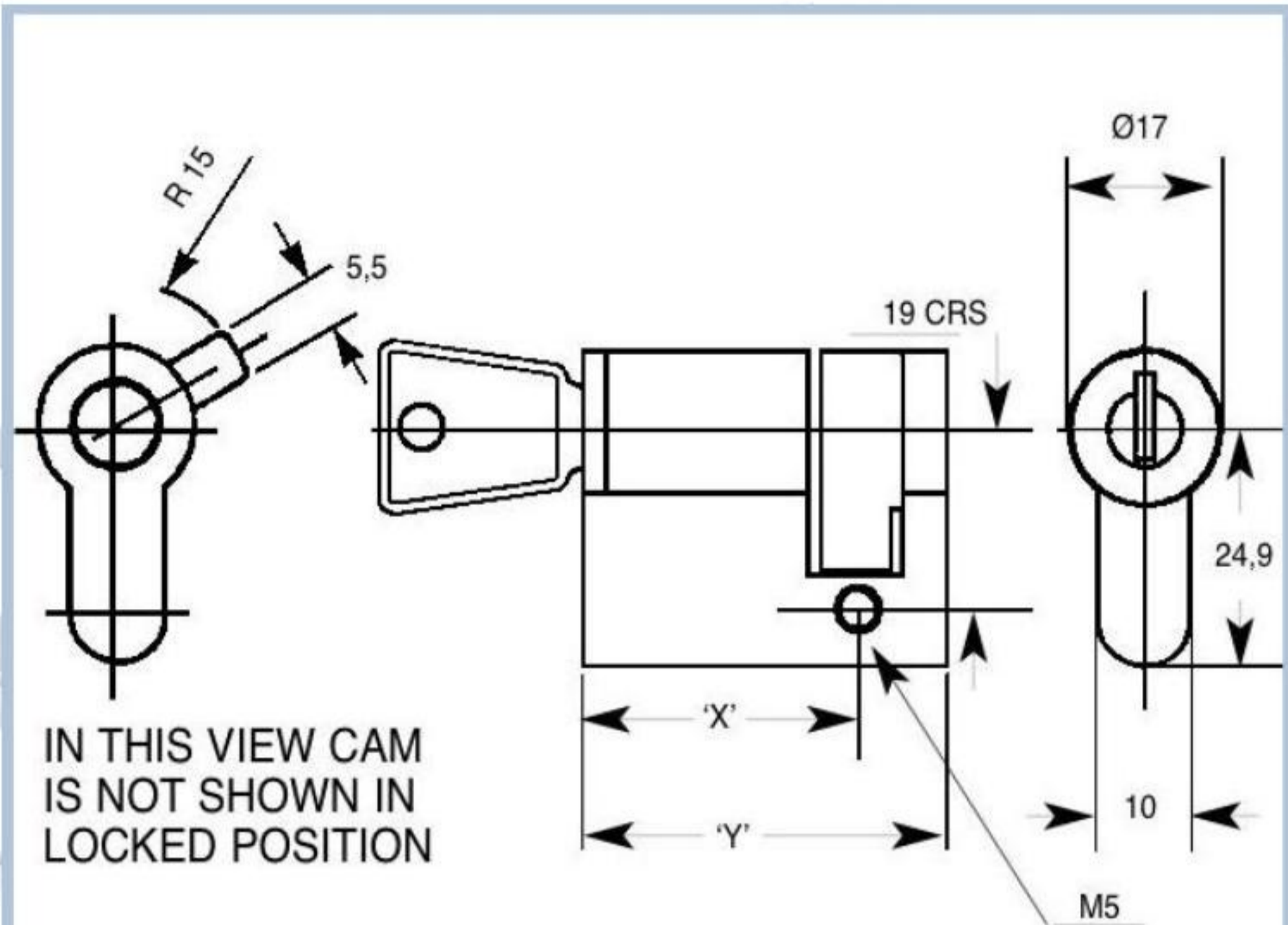

Buy on-line  
at the FA Parkes  
sales portal  
the quickest  
and most efficient  
way to purchase  
all your hardware  
requirements; locks  
handles, hinges  
stays, gasketing  
etc....

[www.faparkes.co.uk](http://www.faparkes.co.uk)  
your one stop shop!



SUPPLIED WITH M5 x 40mm PAN HEAD SCREW

DIMENSION 'X' = DIMENSION 'Y' - 10mm

**PRODUCT REFERENCE NUMBERS**

KEY SERIES	COM-BINATIONS	ASSEMBLY NUMBER		LENGTH (DIM Y)
		ZINC PLATE	CHROME/ BRASS	
92 M	200	3408	-	40 MM
85 M	2000	3409	3411	40 MM
92 M	200	3417	-	50 MM
85 M	2000	3419	3415	50 MM
92 M	200	3420	-	70 MM
85 M	2000	3423	3413	70 MM

**M = MASTER KEY SYSTEM: SUPPLIED TO ORDER ONLY**  
**STANDARD MOVEMENTS: 7 (360° KEY FREE 12 O'CLOCK AND 6 O'CLOCK)**

**STANDARD FINISHES: ZINC PLATE  
CHROME  
BRASS EFFECT**

F.A. Parkes (M.B.F) Limited  
Unit 4, Acorn Court  
Butts Street, Leigh  
Lancashire WN7 3AE

Tel. 01942 681 996  
[sales@faparkes.co.uk](mailto:sales@faparkes.co.uk)