

Snap-in magnets

new!

Snap-in magnets for sheet metal applications. Suitable for material thicknesses 1.6mm or 2.6mm.
 E denotes material thickness.
 Cut-out varies to suit metal thickness.
 Flex-tab for easy removal.



A	B	C	force	part number	material	finish	weight
41	13	14.6	1.2kg	16-7-4208	plastic	black	5g
41	13	14.6	3kg	16-7-4209	plastic	black	5.5g

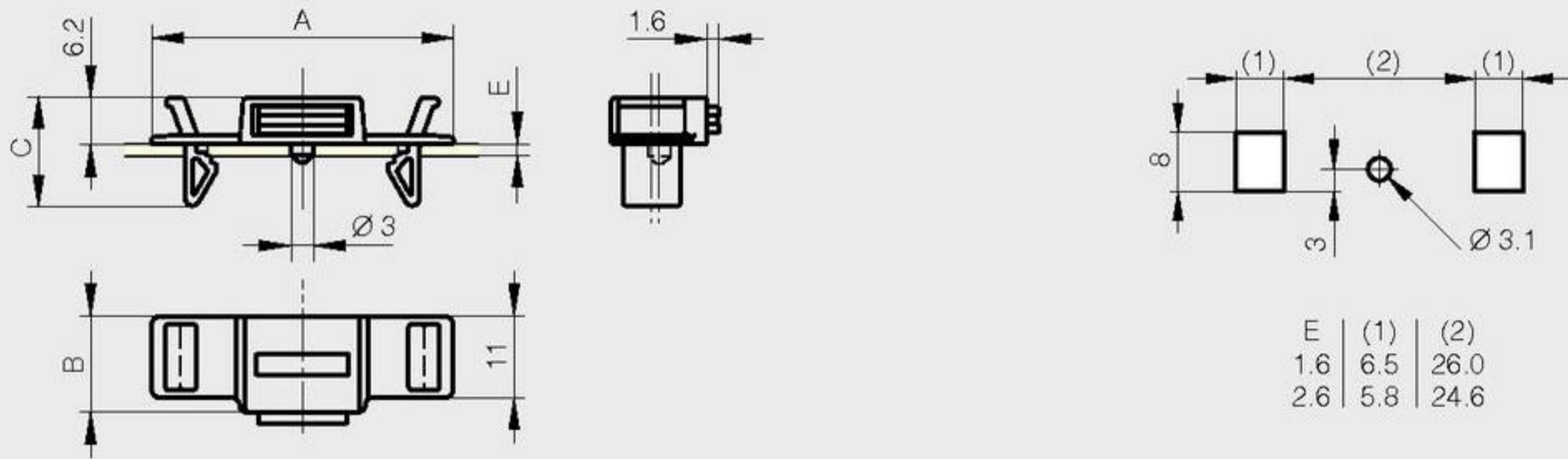

A	B	C	D	E	force	note	part number	material	finish	weight
25.5	12.3	10.4	23	11	1.5kg	for sheetmetal thickness 1.5mm	16-7-4013	polypropylene	white	4g
25.5	9.6	11	23	8.2	1.8kg	for sheetmetal thickness 1.5mm	16-7-4014	polypropylene	white	4g
39.5	10	11	35	8.2	4kg	for sheetmetal thickness 1.5mm	16-7-4015	polypropylene	white	8g
54	12.5	14.5	51.5	10.8	15kg	for sheetmetal thickness 2.0mm	16-7-3674	polypropylene	black	32g

