

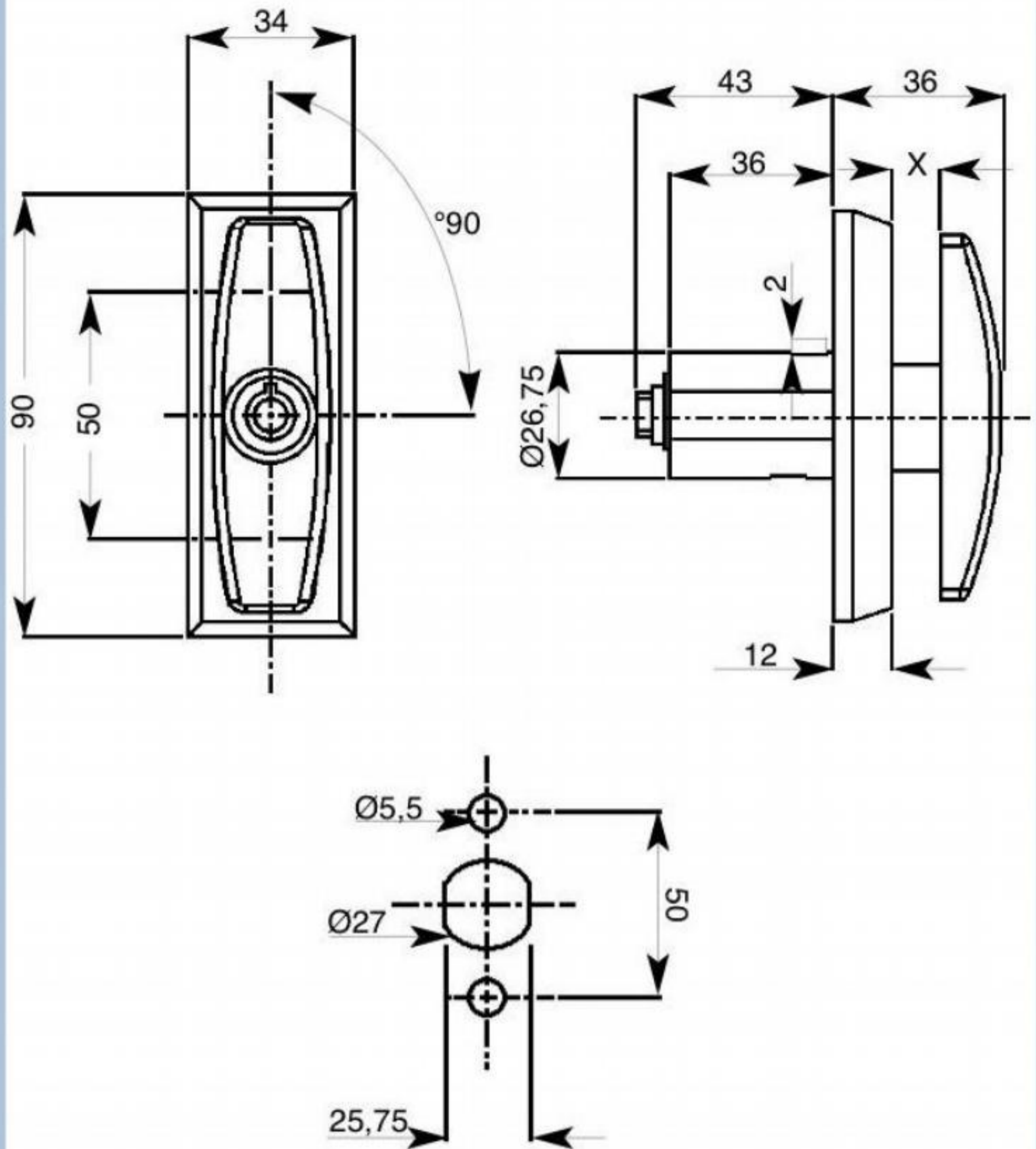

Buy on-line
at the FA Parkes
sales portal
the quickest
and most efficient
way to purchase
all your hardware
requirements; locks
handles, hinges
stays, gasketing
etc....

www.faparkes.co.uk
your one stop shop!



PRODUCT REFERENCE NUMBERS

PART NUMBER	KEY SERIES	COMBINATIONS	"X"
1604	28 M	10000	5MM
1642	28 M	10000	12MM

M = MASTER KEY SYSTEM: SUPPLIED TO ORDER ONLY

STANDARD MOVEMENTS: 90° CLOCKWISE (01) AND 360° CLOCKWISE (07)

STANDARD FINISH: MATT BLACK AND CHROME

8MM SQUARE SPINDLES ARE AVAILABLE IN VARIOUS LENGTHS TO SUIT DIFFERENT DOOR THICKNESS ON REQUEST.

GASKET AVAILABLE - 6700202.

F.A. Parkes (M.B.F) Limited
Unit 4, Acorn Court
Butts Street, Leigh
Lancashire WN7 3AE

Tel. 01942 681 996
sales@faparkes.co.uk