

Aluminium hinges

new!

This hinge has the same footprint as our friction, detent and spring hinges.
 All are fully interchangeable.
 Plastic pin with or without end caps.

A	B	C	D	torque	part number	material	finish	weight
65	55	4.5	13	without cap	72-1-4212	alu 6060 T5	clear anodised	130g
65	55	4.5	13	without cap	72-1-4213	alu 6060 T5	black anodised	130g
65	55	4.5	13	with cap	72-1-4214	alu 6060 T5	clear anodised	130g
65	55	4.5	13	with cap	72-1-4215	alu 6060 T5	black anodised	130g

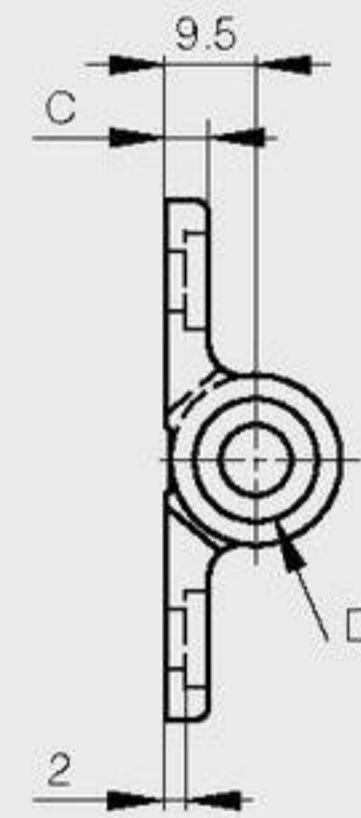
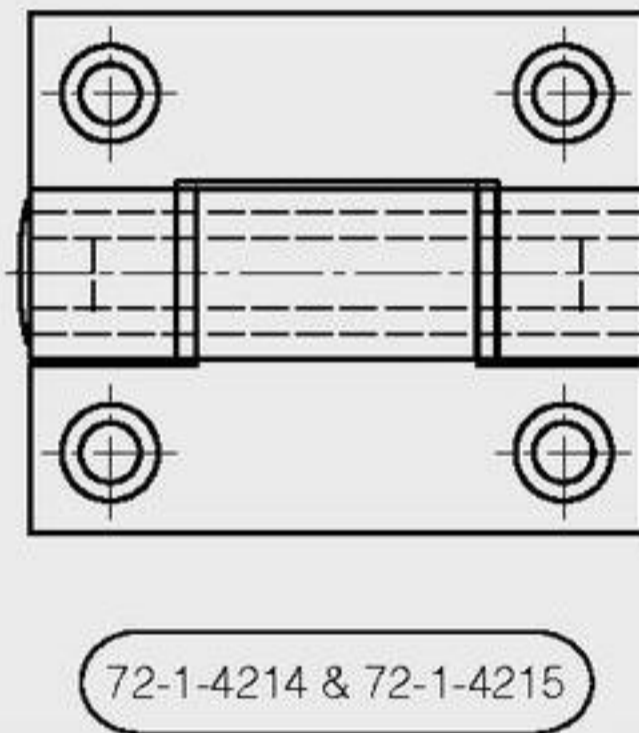
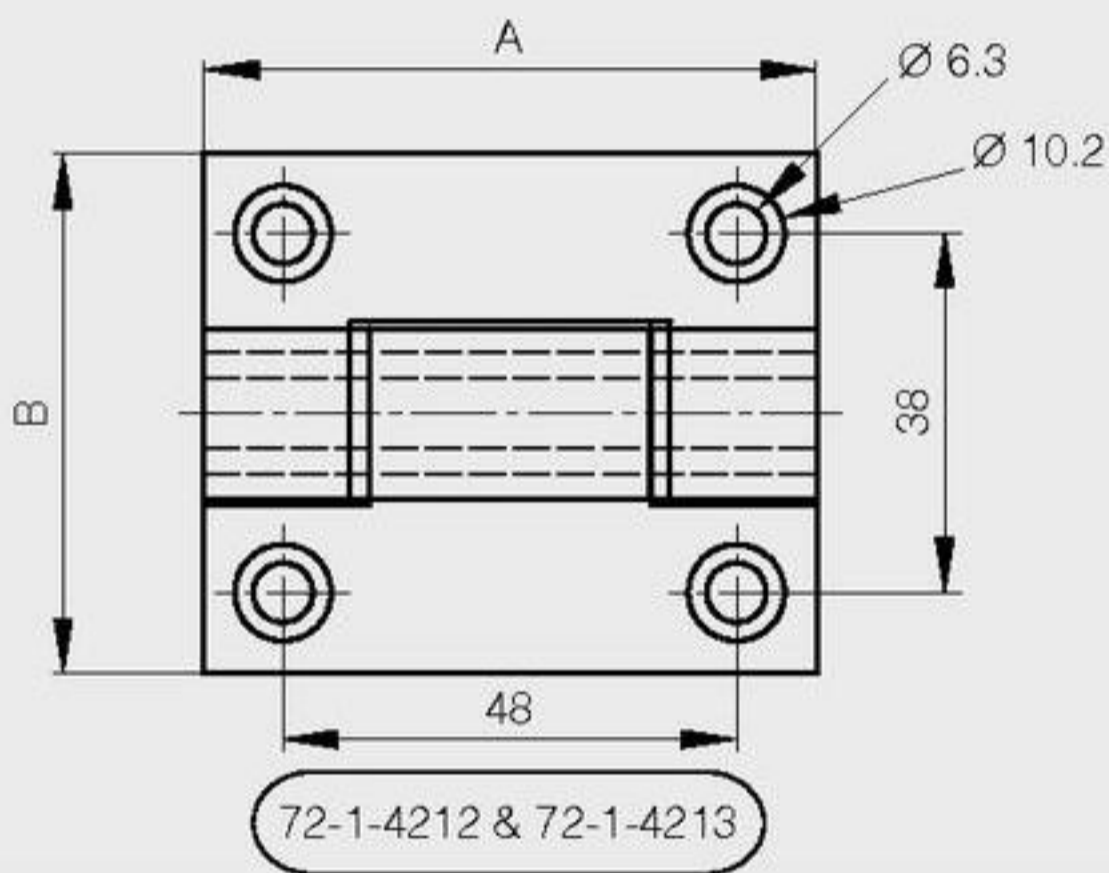

Hinge with 304 stainless steel riveted pin

A	B	C	D	part number	material	finish	weight
32	50	3	5.2	72-1-3635	alu 6060 T5	raw	20g
50	50	3	5.2	72-1-3636	alu 6060 T5	raw	30g

