

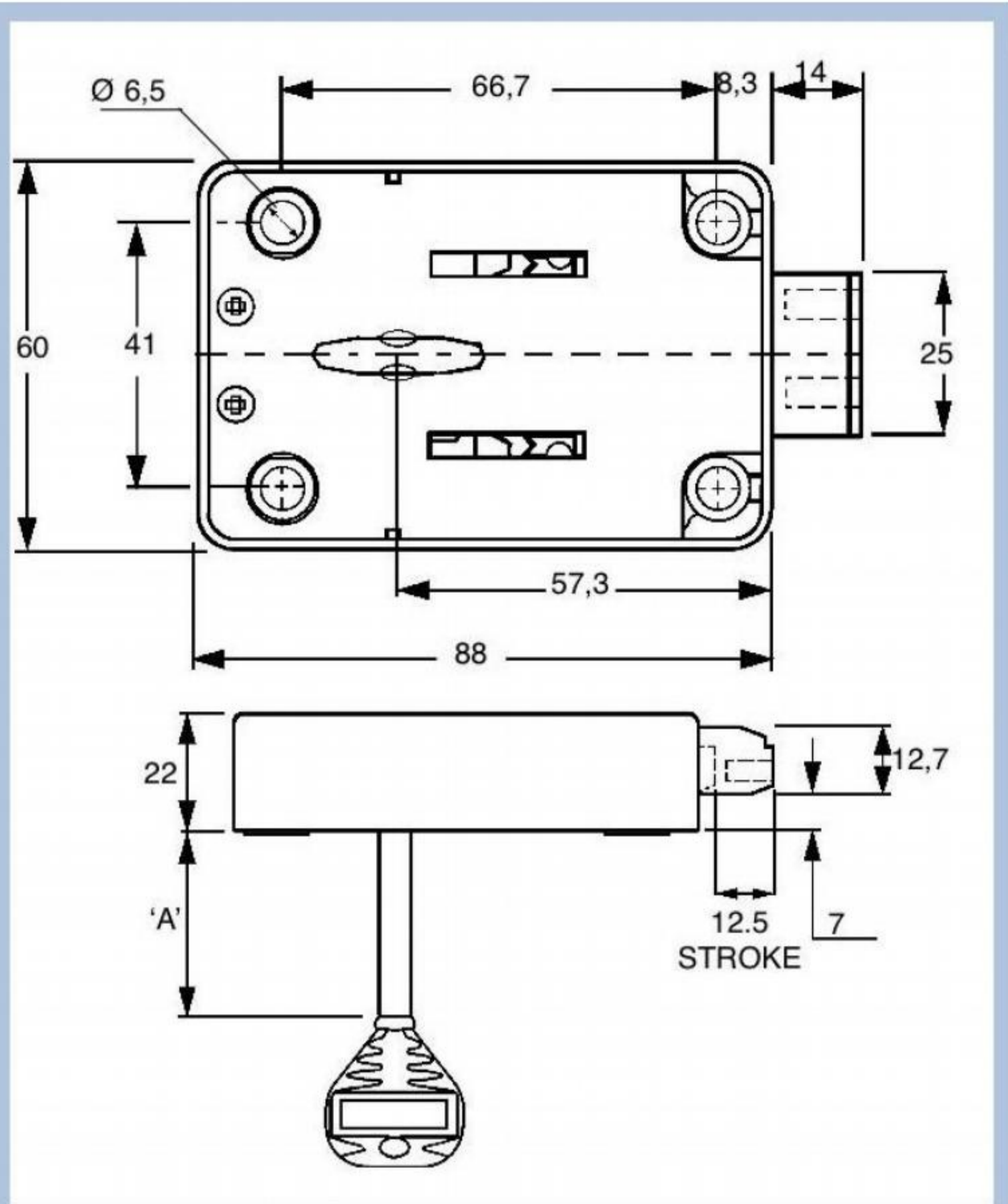

Buy on-line
at the FA Parkes
sales portal
the quickest
and most efficient
way to purchase
all your hardware
requirements; locks
handles, hinges
stays, gasketing
etc....

www.faparkes.co.uk
your one stop shop!



PRODUCT REFERENCE NUMBERS

PRODUCT REFERENCE NUMBERS	KEY SERIES	COMBINATIONS	FIXING
3009060A	SR1	10,000	LEFT EDGE RH HINGED DOOR
3009080A	SR1	10,000	RIGHT EDGE LH HINGED DOOR
3009160A	SR1	10,000	LEFT EDGE RH HINGED DOOR
3009180A	SR1	10,000	RIGHT EDGE LH HINGED DOOR

STANDARD MOVEMENTS: 6, 8

STANDARD FINISH: SELF COLOUR

**DOUBLE BITTED KEY AVAILABLE IN 4 LENGTHS DIMENSION 'A'
15, 40, 70 OR 115, PLEASE SPECIFY WHEN ORDERING.**

KEY RETAINED: 3009060A, 3009080A

KEY REMOVABLE: 3009160A, 3009180A

HIGH PRECISION DIE CAST & PRESSED STEEL COMPONENTS

ANTI-PICK LEVERS FITTED AS STANDARD

HIGH STRENGTH BOLT MAY BE DRILLED & TAPPED AS
REQUESTED.

CAN BE PURCHASED KEYED ALIKE.

F.A. Parkes (M.B.F) Limited
Unit 4, Acorn Court
Butts Street, Leigh
Lancashire WN7 3AE

Tel. 01942 681 996
sales@faparkes.co.uk