

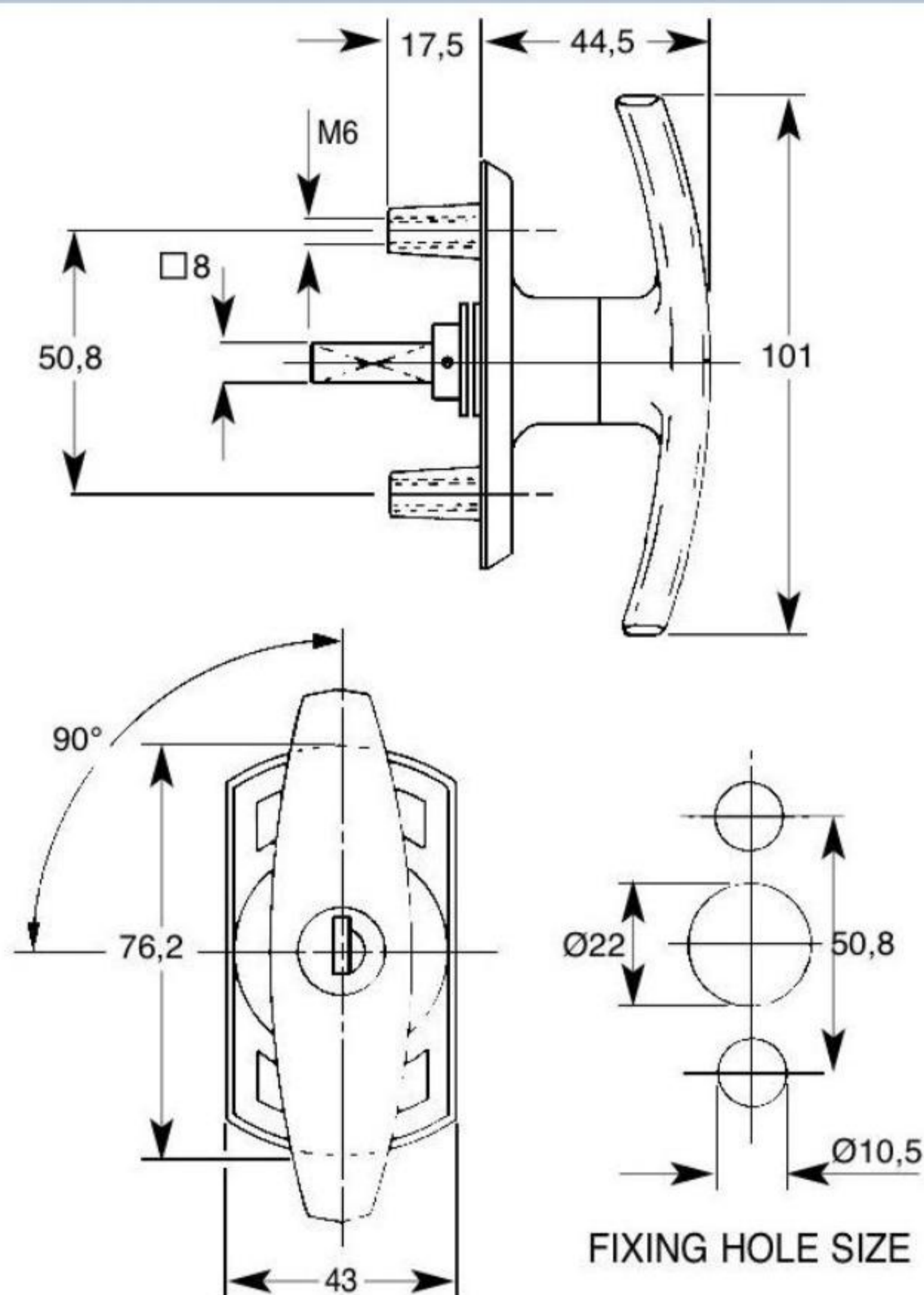

Buy on-line  
at the FA Parkes  
sales portal  
the quickest  
and most efficient  
way to purchase  
all your hardware  
requirements; locks  
handles, hinges  
stays, gasketing  
etc....

[www.faparkes.co.uk](http://www.faparkes.co.uk)  
your one stop shop!



**PRODUCT REFERENCE NUMBERS**

KEY SERIES	COMBINATIONS	REFERENCE No.
<b>WITH SQUARE SPINDLE</b>		
92 M	200	1616
64 M	1000	1816
95-97 M	2000	1716
<b>WITH DIAMOND SPINDLE</b>		
92 M	200	1613

**M = MASTER KEY SYSTEM: SUPPLIED TO ORDER ONLY**

**STANDARD KEY MOVEMENTS: 4**

**STANDARD MOVEMENTS: 1**

**STANDARD FINISHES: SILVER  
MATT BLACK**

F.A. Parkes (M.B.F) Limited  
Unit 4, Acorn Court  
Butts Street, Leigh  
Lancashire WN7 3AE

Tel. 01942 681 996  
[sales@faparkes.co.uk](mailto:sales@faparkes.co.uk)