

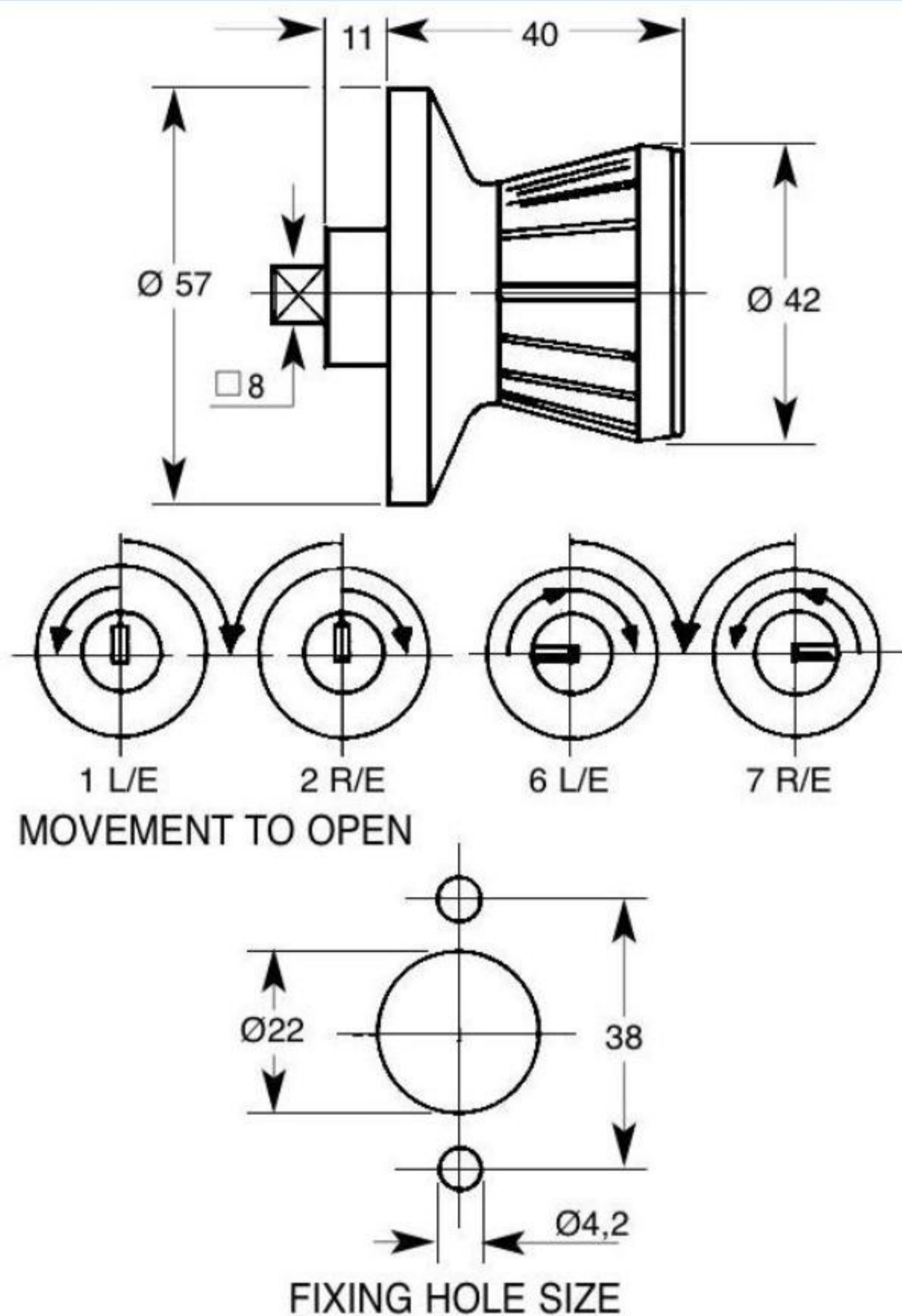

Buy on-line  
at the FA Parkes  
sales portal  
the quickest  
and most efficient  
way to purchase  
all your hardware  
requirements; locks  
handles, hinges  
stays, gasketing  
etc....

[www.faparkes.co.uk](http://www.faparkes.co.uk)  
your one stop shop!



**PRODUCT REFERENCE NUMBERS**

TYPE	KEY SERIES	COMBINATIONS	BLACK PLASTIC GRIP	BROWN PLASTIC GRIP
LOCKING	92 M	200	1605	1665
NON-LOCKING			1623	1664
BLANK			1622	1666

**M** = MASTER KEY SYSTEM: SUPPLIED TO ORDER ONLY

**STANDARD MOVEMENTS:** 1, 2, 6, 7

**STANDARD FINISH:** SATIN CHROME

**FOR ACCESSORIES AND STANDARD MOVEMENTS  
& SPINDLE DETAILS: SEE SECTION 12**

F.A. Parkes (M.B.F) Limited  
Unit 4, Acorn Court  
Butts Street, Leigh  
Lancashire WN7 3AE

Tel. 01942 681 996  
[sales@faparkes.co.uk](mailto:sales@faparkes.co.uk)