



Buy on-line  
at the FA Parkes  
sales portal  
the quickest  
and most efficient  
way to purchase  
all your hardware  
requirements; locks  
handles, hinges  
stays, gasketing  
etc....

[www.faparkes.co.uk](http://www.faparkes.co.uk)  
your one stop shop!



9/01433 & 9/01463  
Emergency stop  
switch assembled into  
recess pan



Rear-view of  
assembled switch and  
recess pan

### ORDERING CODE

- 9/01433** Emergency-stop pan & gasket  
**9/01463** Emergency-stop switch & contact block

### SPECIFICATION

<b>A</b>	Pan total width	125 mm
<b>B</b>	Hole centres	90 mm
<b>C</b>	Projection, button	13 mm
<b>D</b>	Total depth of pan	43 mm
<b>E</b>	Projection, contactor	16 mm
<b>F</b>	Diameter, 'cup'	80 mm
<b>H</b>	Hole sizes (dia)	4.75 mm, c/s 9 mm

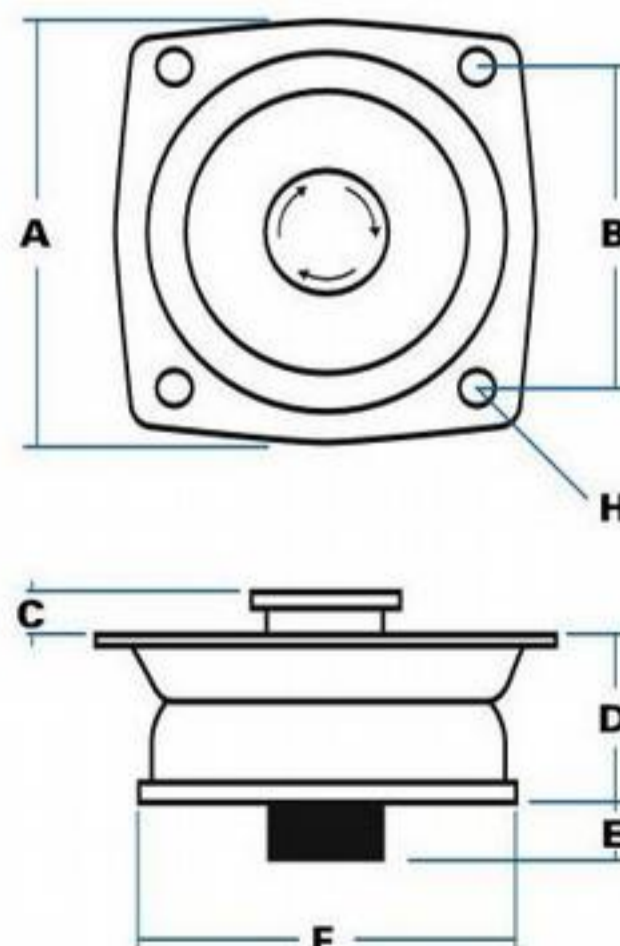

Illustration shows switch and pan in assembled condition, (without gasket for clarity).



Push-button switch and connector block are supplied as separate parts, to be fitted through pan aperture and assembled.

F.A. Parkes (M.B.F) Limited  
Unit 4, Acorn Court  
Butts Street, Leigh  
Lancashire WN7 3AE

Tel. 01942 681 996  
[sales@faparkes.co.uk](mailto:sales@faparkes.co.uk)