

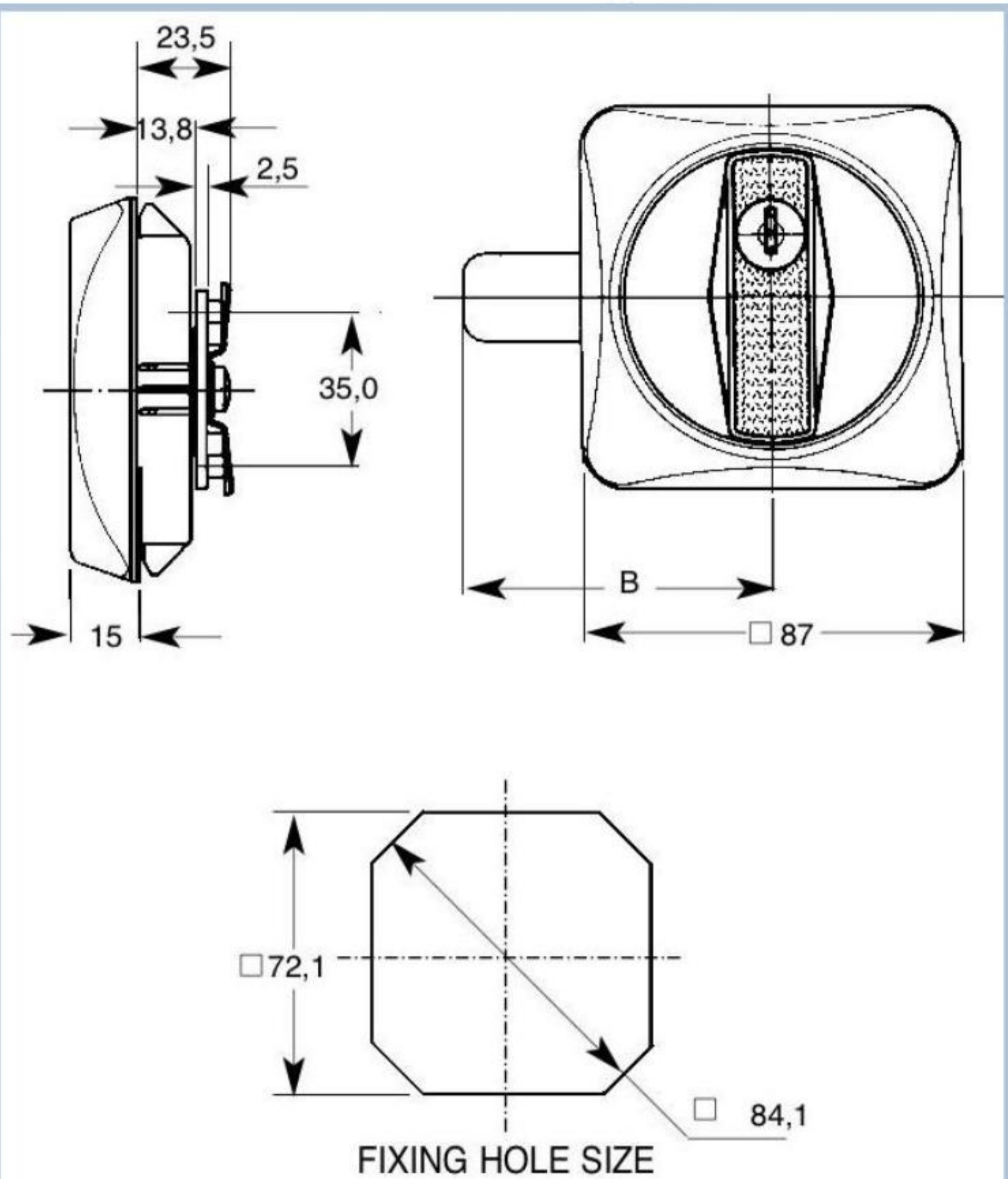

Buy on-line  
at the FA Parkes  
sales portal  
the quickest  
and most efficient  
way to purchase  
all your hardware  
requirements; locks  
handles, hinges  
stays, gasketing  
etc....

[www.faparkes.co.uk](http://www.faparkes.co.uk)  
your one stop shop!



**PRODUCT REFERENCE NUMBERS**

KEY SERIES	COMBINATIONS	LOCKING	NON-LOCKING	FIXED	PANEL THICKNESS
9000 D/E M	500	F90	F91/F241	F92	0.8-1.2
95-97 M	2000	1791*/F237			0.8-1.2
92 M	200	1691*/F236			0.8-1.2
18 M	200	5835*			0.8-1.2
25 M	2000	F534			0.8-1.2

**M = MASTER KEY SYSTEM: SUPPLIED TO ORDER ONLY**

**STANDARD MOVEMENTS: 08**

**STANDARD FINISHES: BLACK ROSE**

SATIN HANDLE

\*BRIGHT CHROME HANDLE ONLY

THIS PRODUCT IS QUICK FIXING, SUITABLE FOR PANEL THICKNESS SHOWN ABOVE.

F.A. Parkes (M.B.F) Limited  
Unit 4, Acorn Court  
Butts Street, Leigh  
Lancashire WN7 3AE

Tel. 01942 681 996  
[sales@faparkes.co.uk](mailto:sales@faparkes.co.uk)