



Buy on-line
at the FA Parkes
sales portal
the quickest
and most efficient
way to purchase
all your hardware
requirements; locks
handles, hinges
stays, gasketing
etc....

www.faparkes.co.uk
your one stop shop!



F.A. Parkes (M.B.F) Limited
Unit 4, Acorn Court
Butts Street, Leigh
Lancashire WN7 3AE

Tel. 01942 681 996
sales@faparkes.co.uk

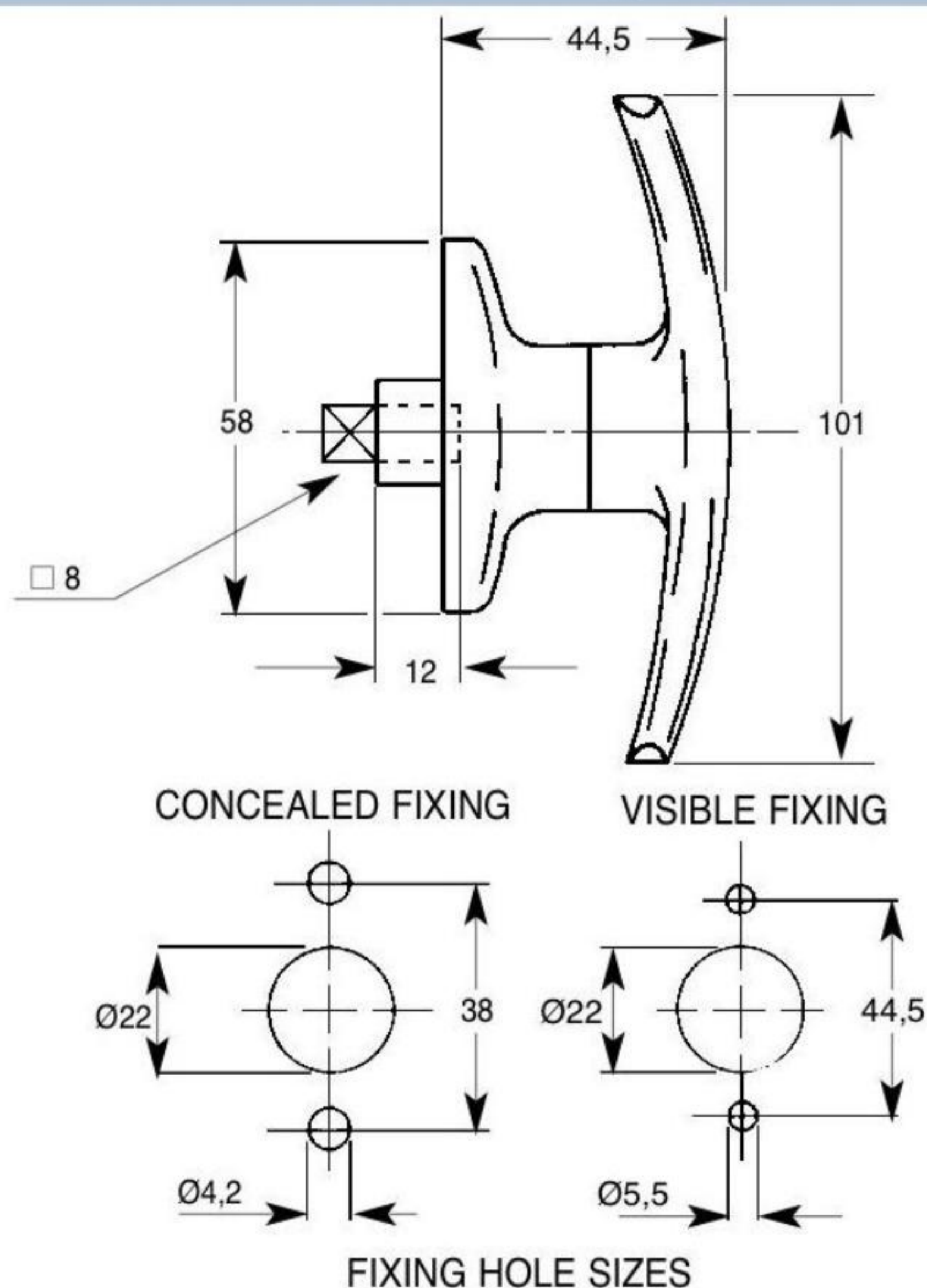

| PRODUCT REFERENCE NUMBERS | | | | |
|---------------------------|------------|--------------|-------------------|--------------|
| TYPE | KEY SERIES | COMBINATIONS | STANDARD ASSEMBLY | CAULKING CAM |
| STANDARD VERSION | | | | |
| NON-LOCKING | | | 1625 (1639) | 1628 |
| FIXED | | | 1626 (1640) | |
| SHUTTERED VERSION | | | | |
| LOCKING | 92 M | 200 | 1617 (1638) | 1627 |
| | 95/97 M | 2000 | 1717 (1738) | |
| | 64 D/E M | 1000 | 1877 (1878) | 1879 |

M = MASTER KEY SYSTEM: SUPPLIED TO ORDER ONLY
STANDARD FINISHES: EPOXY, BRIGHT CHROME
 ELECTROPHORETIC
 REF Nos IN () REFER TO LOCKS WITH VISIBLE FIXING
FOR ACCESSORIES AND STANDARD MOVEMENTS
& SPINDLE DETAILS: SEE SECTION 12