

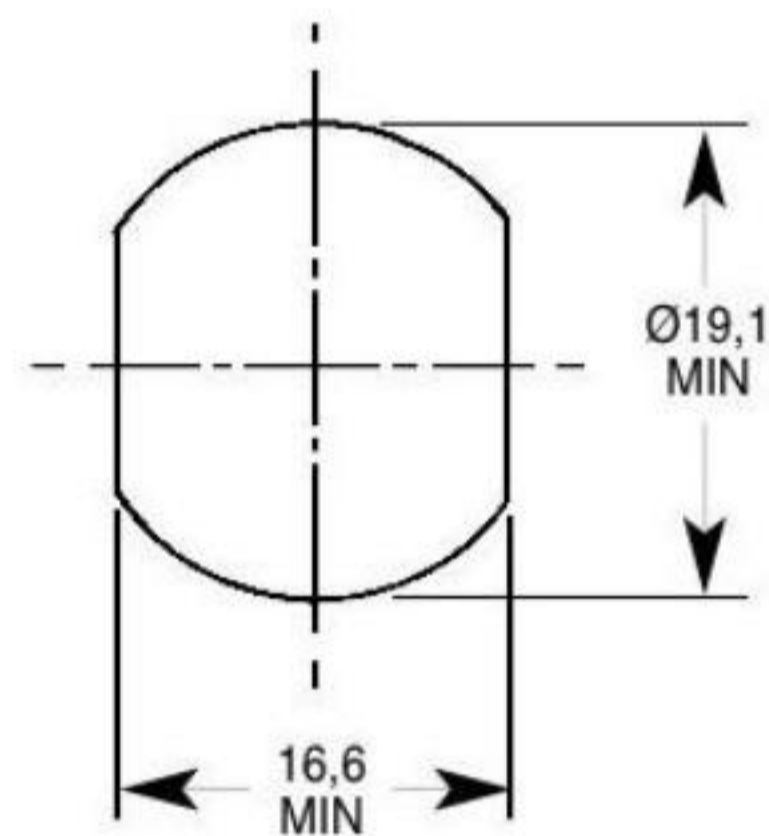

Buy on-line  
at the FA Parkes  
sales portal  
the quickest  
and most efficient  
way to purchase  
all your hardware  
requirements; locks  
handles, hinges  
stays, gasketing  
etc....

[www.faparkes.co.uk](http://www.faparkes.co.uk)  
your one stop shop!

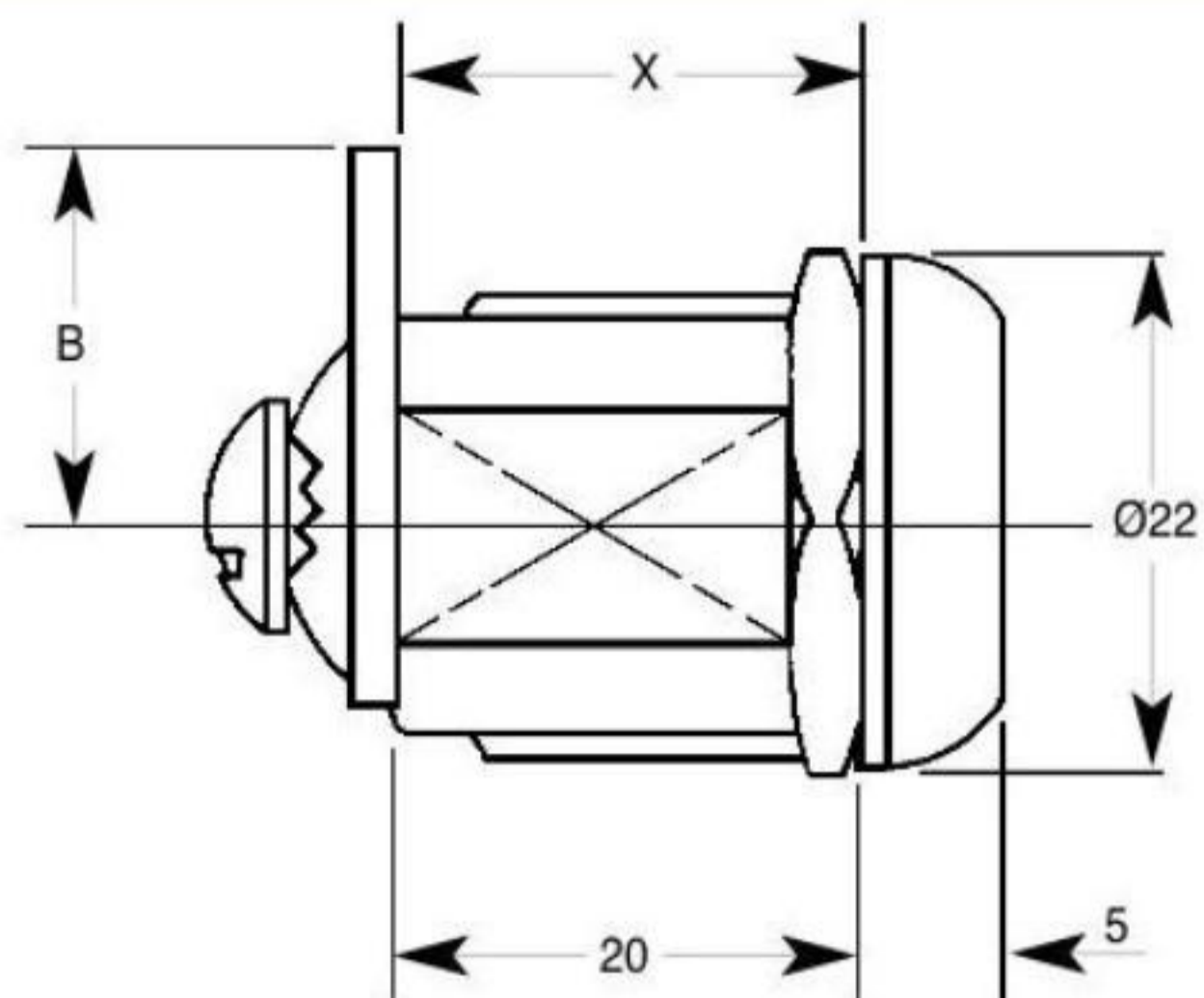

FIXING HOLE SIZE

**PRODUCT REFERENCE NUMBERS**

	NUT FIXED HOUSING	SNAP-IN FIXING	HORSESHOE CLIP FIXING
<b>HEAD SHAPE</b>	ROUND	SQUARE	SQUARE
	4412	4415	4420

**STANDARD MOVEMENTS:** 1, 2, 3, 4

**STANDARD FINISHES:** BRIGHT CHROME  
STAINLESS STEEL CAP ON  
4412 ONLY

FOR USE ON DOORS AND REMOVABLE INSPECTION  
PANELS IN ELECTRICAL INSTALLATIONS, OPERABLE BY  
A COIN OR SCREWDRIVER

F.A. Parkes (M.B.F) Limited  
Unit 4, Acorn Court  
Butts Street, Leigh  
Lancashire WN7 3AE

Tel. 01942 681 996  
[sales@faparkes.co.uk](mailto:sales@faparkes.co.uk)