



Buy on-line
at the FA Parkes
sales portal
the quickest
and most efficient
way to purchase
all your hardware
requirements; locks
handles, hinges
stays, gasketing
etc....

www.faparkes.co.uk
your one stop shop!

9/01505
Single-point model in
'rest' position.



ORDERING CODE

Stainless Steel Models

9/01505 LH, non-locking, stainless steel

9/01506 RH, non-locking, stainless steel

Mild Steel Models

9/01515 LH, non-locking, zinc-plated

9/01516 RH, non-locking, zinc-plated

SPECIFICATION

Standard model shown with 'cranked down' latch bar

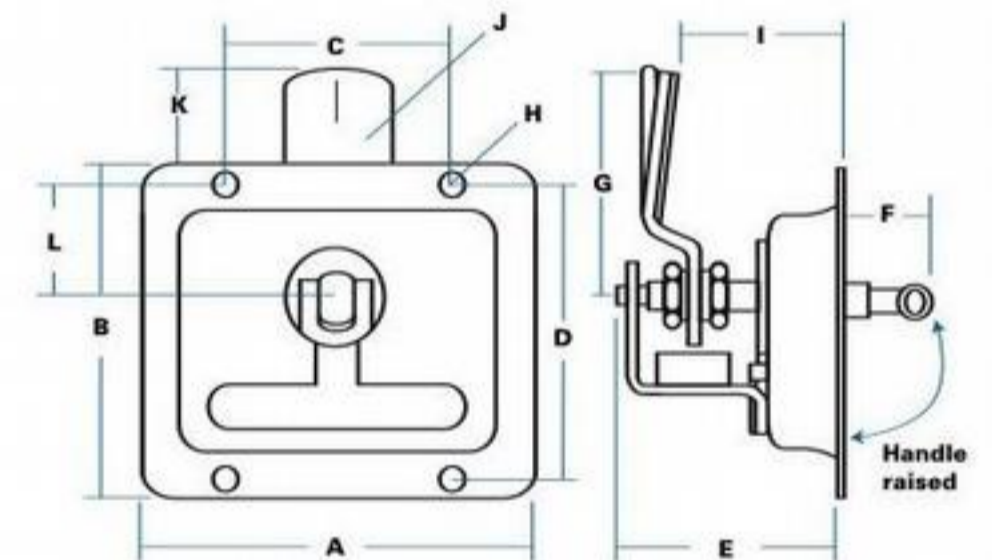

Directions of Movement

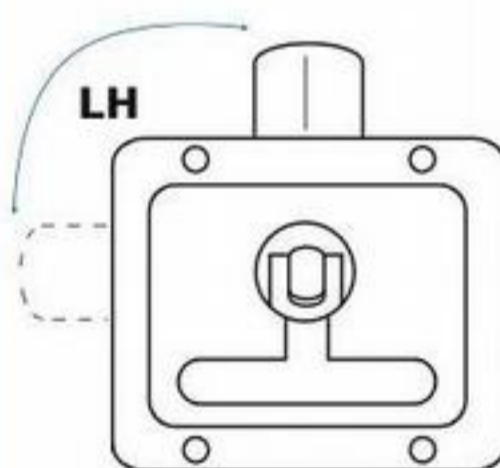

Handle turns
anticlockwise to
release the latch
tongue

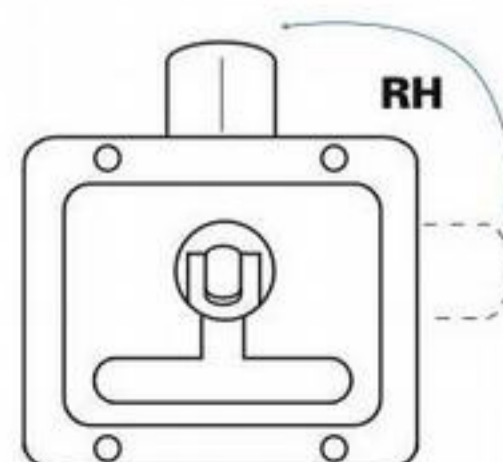

Handle turns
clockwise to
release the latch
tongue

A	Width of pan	120 mm
B	Length of pan	102 mm
C	Hole centres	69 mm
D	Hole centres	90 mm
E	Max. depth	68 mm
F	Height of handle	30 mm
G	Length of latch	70 mm
H	Hole Size (dia)	7.5 mm
I	Engagement (normally set at 51 mm)	43-55 mm
J	Width cam travel 3 mm depth	30 x 5 mm deep
K	Projection	30 mm
L	Location	34 mm
I'	dimension can be varied using different latch bars. See options	

Gasket ref: MP00568 (non-locking)

F.A. Parkes (M.B.F) Limited
Unit 4, Acorn Court
Butts Street, Leigh
Lancashire WN7 3AE

Tel. 01942 681 996
sales@faparkes.co.uk