



Buy on-line
at the FA Parkes
sales portal
the quickest
and most efficient
way to purchase
all your hardware
requirements; locks
handles, hinges
stays, gasketing
etc....

www.faparkes.co.uk
your one stop shop!



9/01501
Single-point model
showing standard latch
bar and adjustment nuts

ORDERING CODE

Stainless Steel Models

9/01501 LH, locking (Mixed differ)

9/01502 RH, locking (Mixed differ)

9/01503 LH, standard-key FS880

9/01504 RH, standard-key FS880

Mild Steel models

9/01511 LH, locking (Mixed differ)

9/01512 RH, locking (Mixed differ)

9/01513 LH, standard-key FS880

9/01514 RH, standard-key FS880

Non-locking models shown opposite

SPECIFICATION

Standard model with 'cranked down' latch bar.

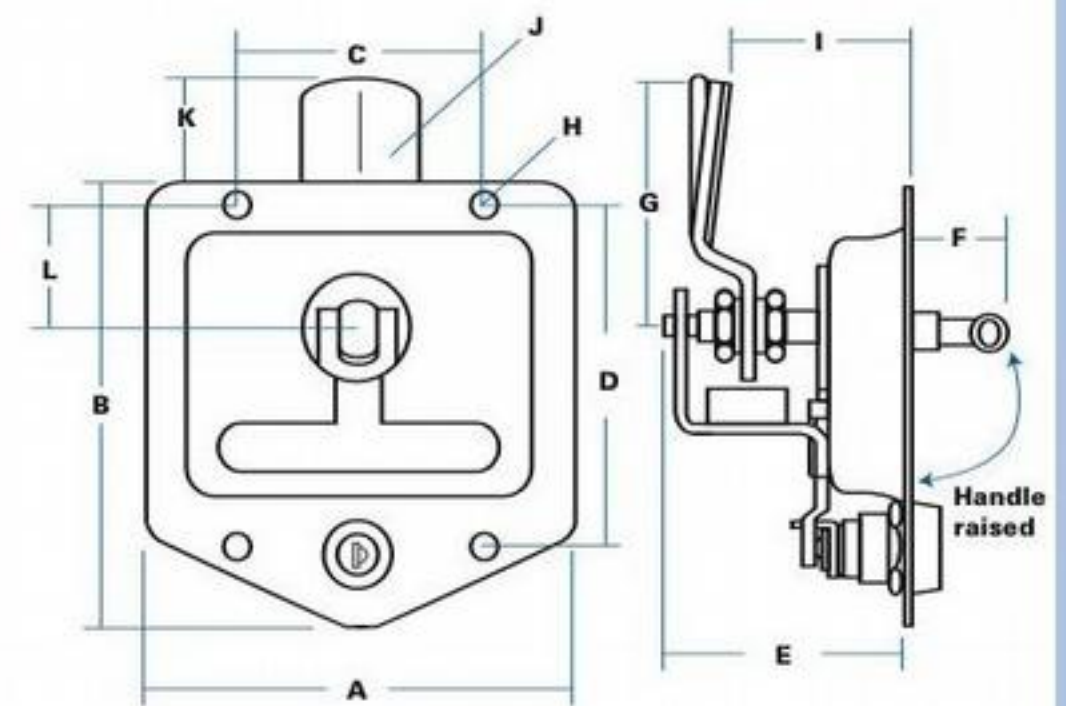

A Width of pan	120 mm
B Length of pan	125 mm
C Hole centres	69 mm
D Hole centres	95 mm
E Max. depth	68 mm
F Height of handle	30 mm
G Length of latch	70 mm
H Hole Size (dia)	7.5 mm
I Engagement (normally set at 51 mm)	43-55 mm
J Width cam travel 3 mm depth	30 x 5 mm deep
K Projection	30 mm
L Location	34 mm

'I' dimension can be varied using different latch bars. See options.

Gasket ref: MP00450 (locking)

Direction of Movement

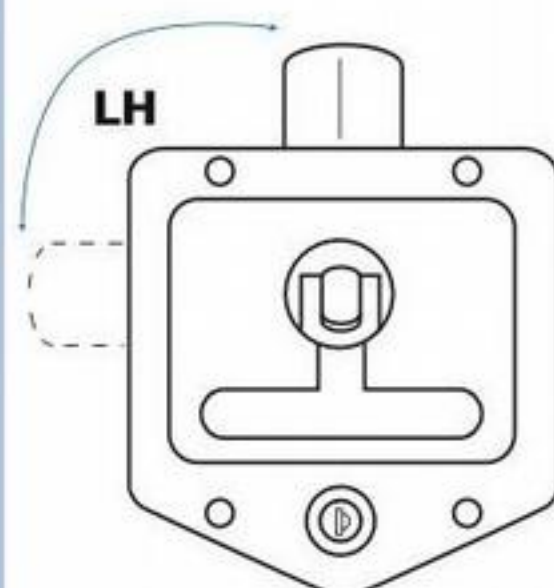

Handle turns
anticlockwise to
release the latch
tongue

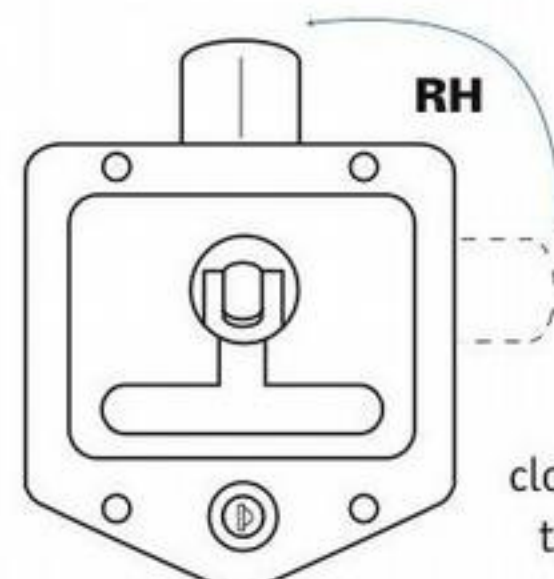

Handle turns
clockwise to release
the latch tongue

F.A. Parkes (M.B.F) Limited
Unit 4, Acorn Court
Butts Street, Leigh
Lancashire WN7 3AE

Tel. 01942 681 996
sales@faparkes.co.uk