



Buy on-line
at the FA Parkes
sales portal
the quickest
and most efficient
way to purchase
all your hardware
requirements; locks
handles, hinges
stays, gasketing
etc....

www.faparkes.co.uk
your one stop shop!



9/01351
Holdback and
Striker pin



9/01351/02
Remote-operated model, with
steel lever and cable-hole.

ORDERING CODE

9/01351	Door holdback & striker pin
9/01351/01	Holdback & pin, handle unattached
9/01351/02	Holdback & pin, remote-operated
5/01664	Moulded handle only, red

An adjustable striker can be provided,
with moulded buffer. Ask for details.

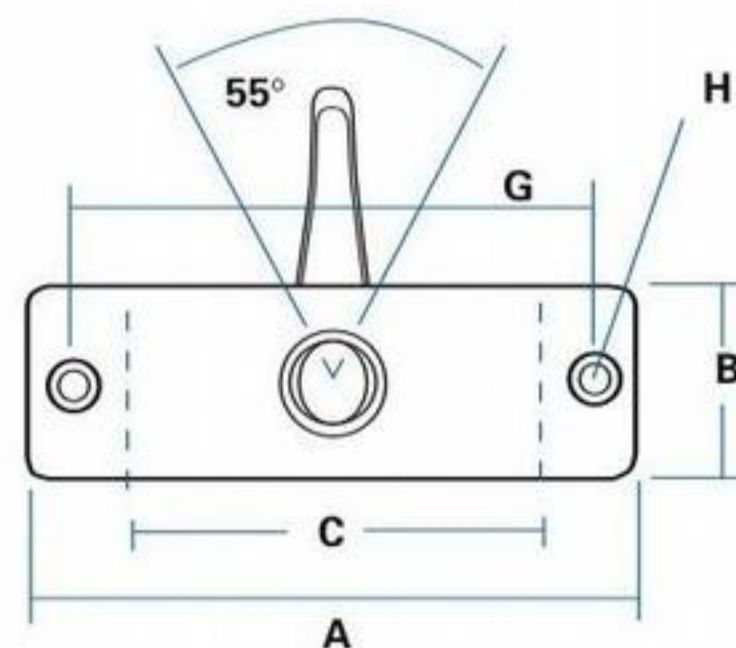

SPECIFICATION

A	Total Width	124mm
B	Faceplate Height	42mm
C	Case Width	94mm
D	Case Depth	22mm
E	Handle Height	60mm
F	Max. Depth	67mm
G	Hole Centres	106mm
H	Hole Dimensions	6.5mm
J	Striker Total Length	47mm
K	Closing Length	27mm

Faceplate: Steel, powder-coated.
Gasket: Closed-cell foam
Body: Acetal copolymer.

Striker pin, Machined steel, hardened and
zinc-plated.

M8 nut, spring washer
& 2-off 30mm washers
provided

Striker pin
diameter = 8mm

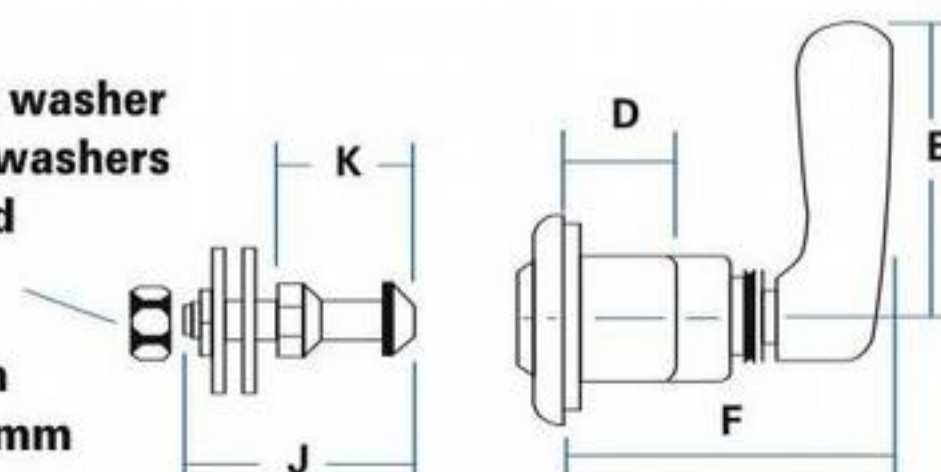

F.A. Parkes (M.B.F) Limited
Unit 4, Acorn Court
Butts Street, Leigh
Lancashire WN7 3AE

Tel. 01942 681 996
sales@faparkes.co.uk