

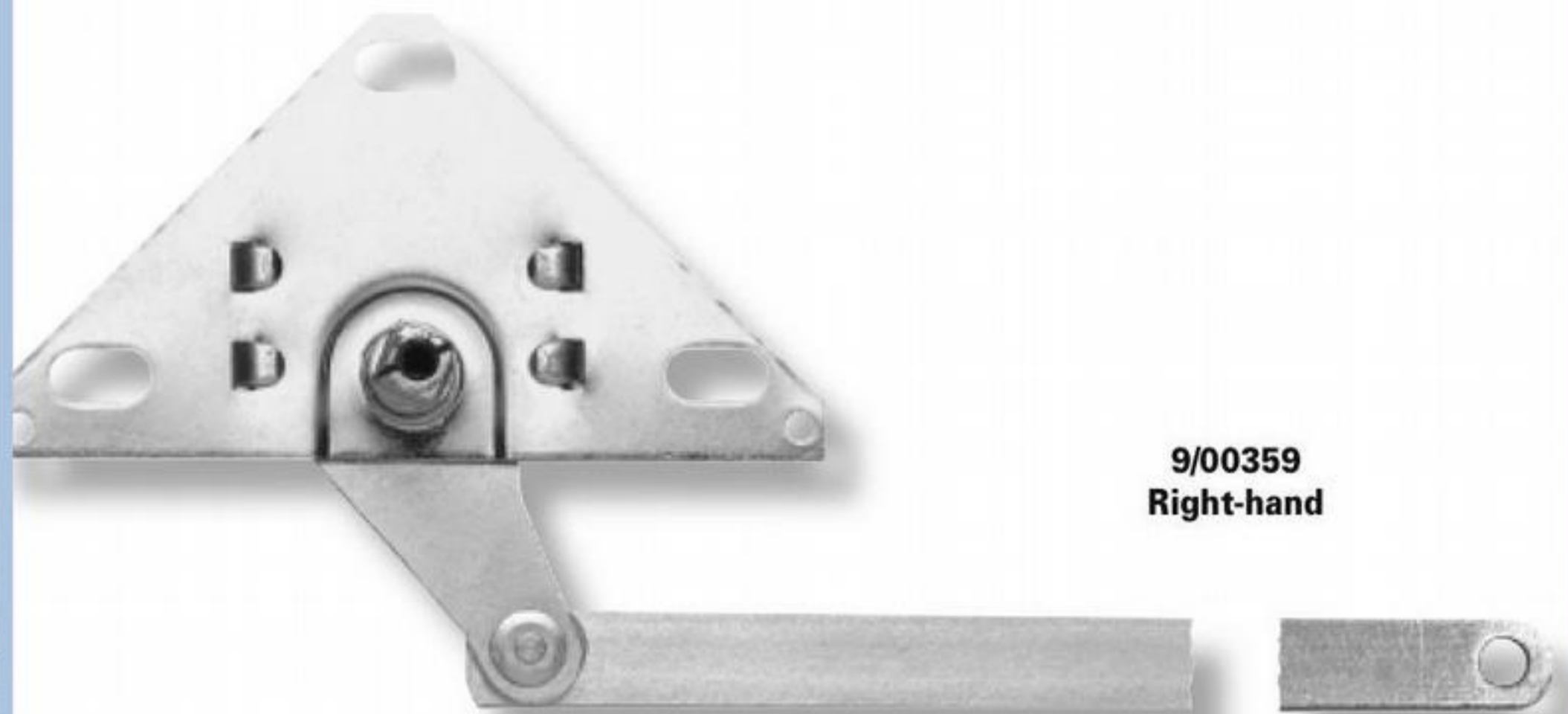

Buy on-line
at the FA Parkes
sales portal
the quickest
and most efficient
way to purchase
all your hardware
requirements; locks
handles, hinges
stays, gasketing
etc....

www.faparkes.co.uk
your one stop shop!



9/00359
Right-hand

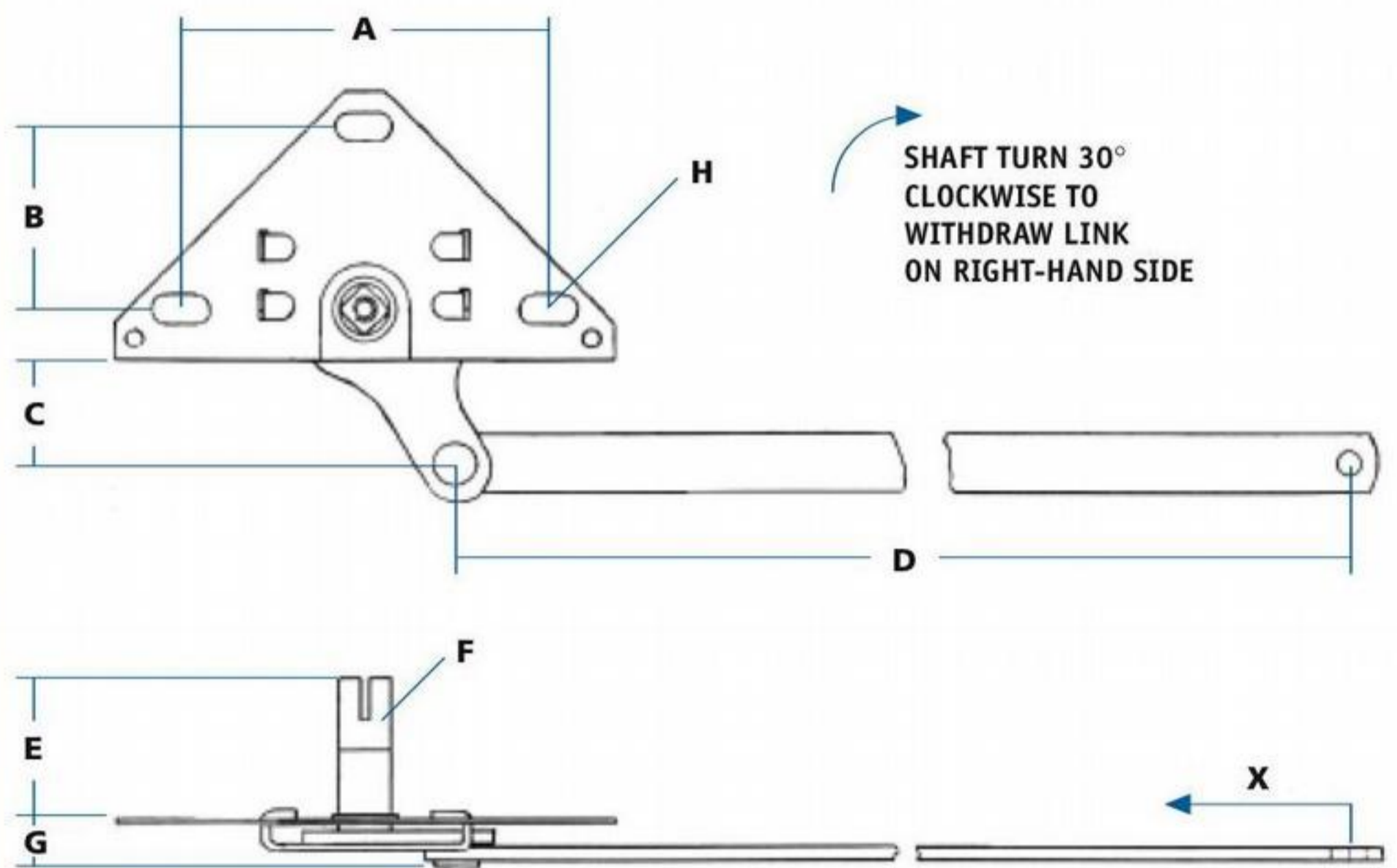

ORDERING CODE

9/00359 Inside release, RH

9/00360 Inside release, LH

SPECIFICATION

A Length (between centres)	80 mm
B Width (between centres)	40 mm
C Projection	22.5 mm
D Link bar	380 mm
E Spindle height	32 mm
F Spindle tapped	15 mm x 10-32 UNF
G Rear projection	10 mm
H Hole sizes	6 x 13 mm
X Travel of latch release	25 mm

F.A. Parkes (M.B.F) Limited
Unit 4, Acorn Court
Butts Street, Leigh
Lancashire WN7 3AE

Tel. 01942 681 996
sales@faparkes.co.uk