



Buy on-line
at the FA Parkes
sales portal
the quickest
and most efficient
way to purchase
all your hardware
requirements; locks
handles, hinges
stays, gasketing
etc....

www.faparkes.co.uk
your one stop shop!

'FT' Keys
Optional



9/00147
Non-locking Large 'T'
38mm concealed
fixing



Single-sided 'FS'
keys are standard



9/00144
Locking 'Large T'
38mm open fixing

ORDERING CODE

With 38 mm open-fixing

9/00144	Large 'T', locking, chrome
9/00144/01	As above, FS 880
9/00145	Large 'T', non-locking, chrome

With 38 mm concealed-fixing

9/00146	Large 'T', locking, chrome
9/00146/01	As above, FS 880
9/00147	Large 'T', non-locking, chrome

With 44 mm open-fixing

9/00244	Large 'T', locking, chrome
9/00244/01	As above, FS 880
9/00245	Large 'T', non-locking, chrome

SPECIFICATION

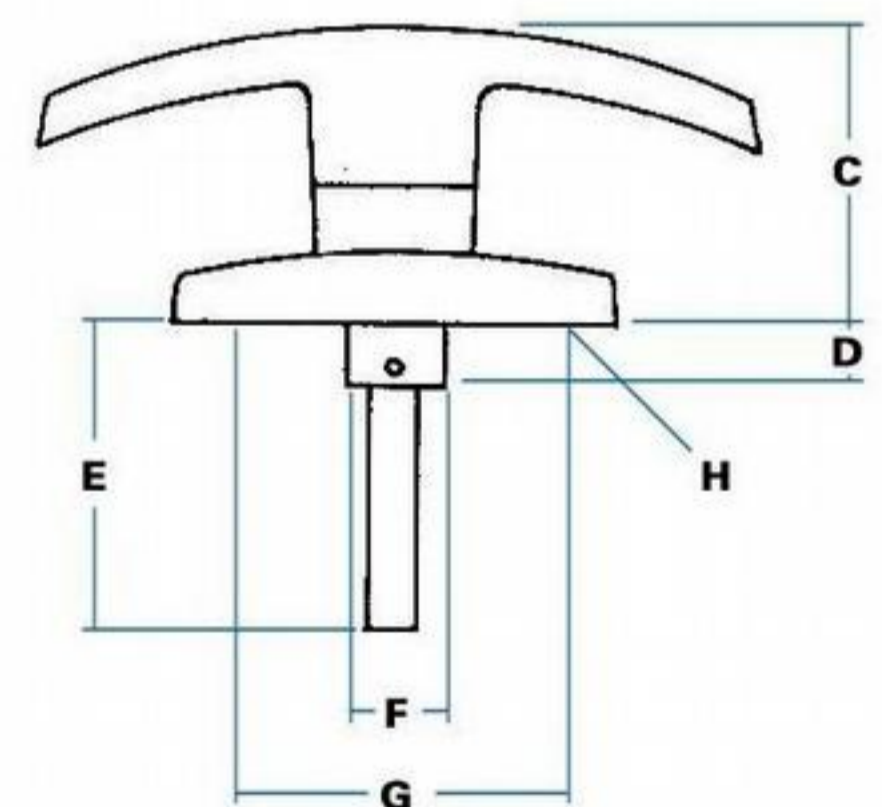
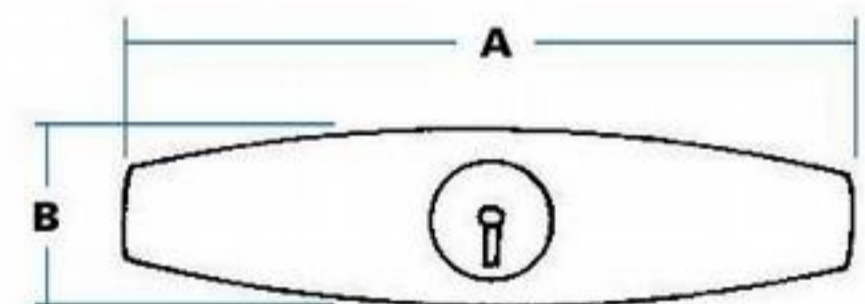

ROTATION OF HANDLES

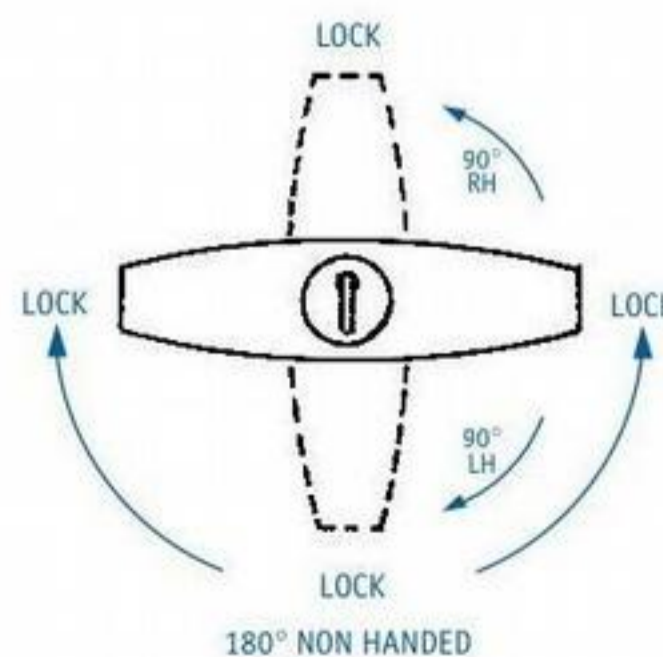

Handles operate through 180° as standard (non-handed). To special order, rotation can be limited to 90° LH (clockwise) or 90° RH (anticlockwise). Handles will lock at each 90° position.

A Handle length	100 mm
B Mounting width	33 mm
C Face height	42 mm
D Depth of handle boss	10 mm
E Shaft length	125 mm
F Diameter of boss	14 mm
G Hole centres	38/44 mm
H Hole sizes (open) dia.	5 mm, c/s 9 mm

F.A. Parkes (M.B.F) Limited
Unit 4, Acorn Court
Butts Street, Leigh
Lancashire WN7 3AE

Tel. 01942 681 996
sales@faparkes.co.uk