

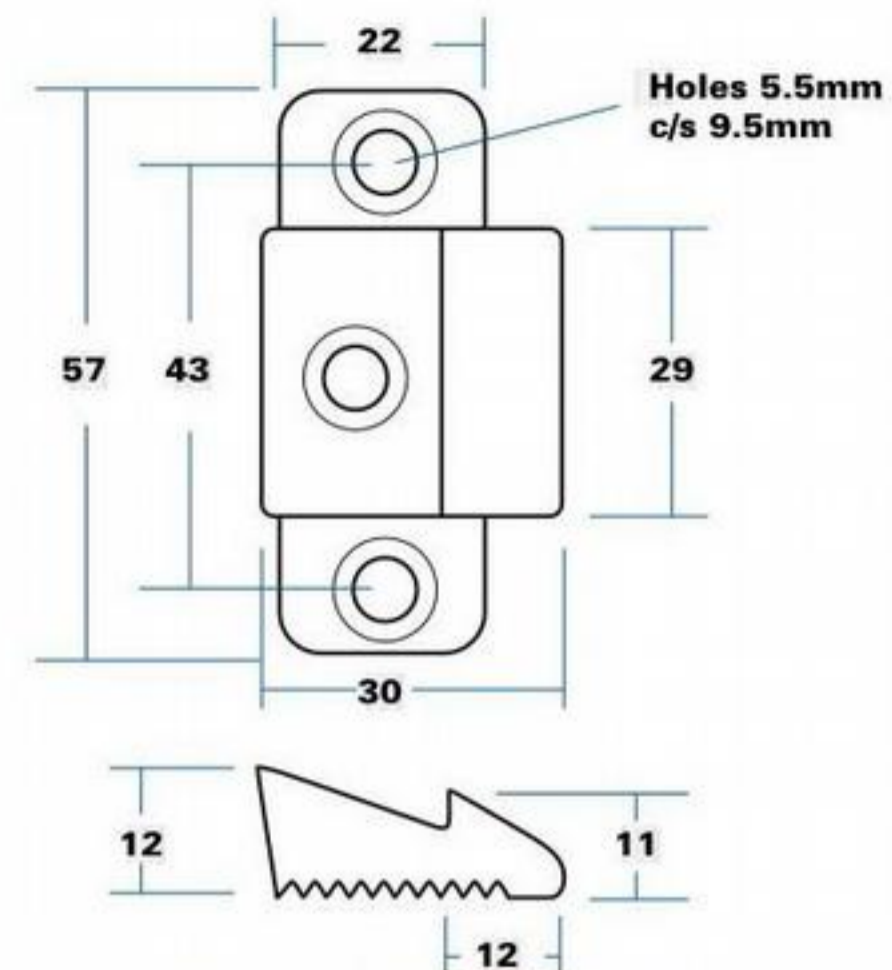

Buy on-line  
at the FA Parkes  
sales portal  
the quickest  
and most efficient  
way to purchase  
all your hardware  
requirements; locks  
handles, hinges  
stays, gasketing  
etc....  
[www.faparkes.co.uk](http://www.faparkes.co.uk)  
your one stop shop!

1/27106  
(Serrated base)



Versatile 2-step design, used with "Mini" slam latches and similar models.

1/27107  
(Serrated base)

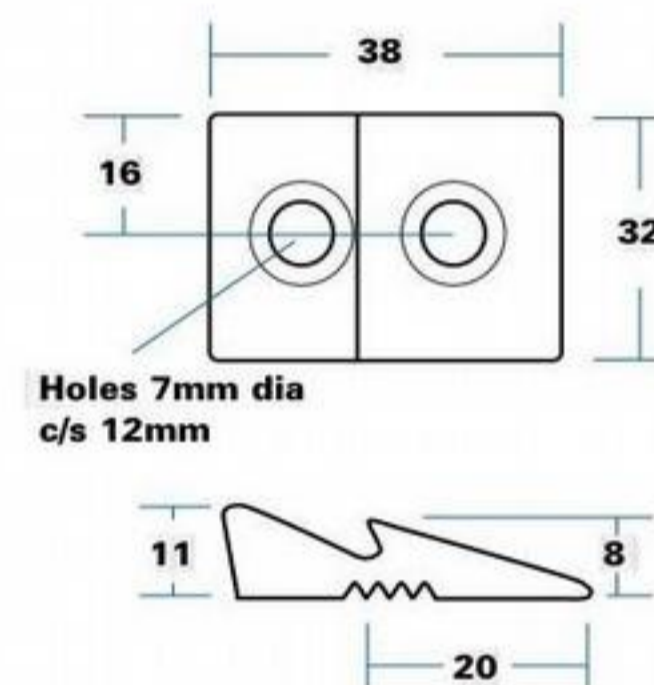
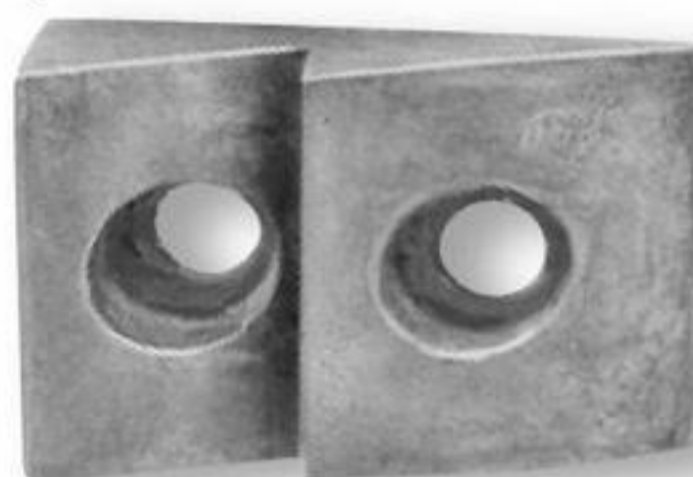

2-step striker for thicker doors/frames with longer depth of travel for full closure. Suits 'Mark 50' heavy-duty slam latches, etc.

1/27113  
(Serrated base)

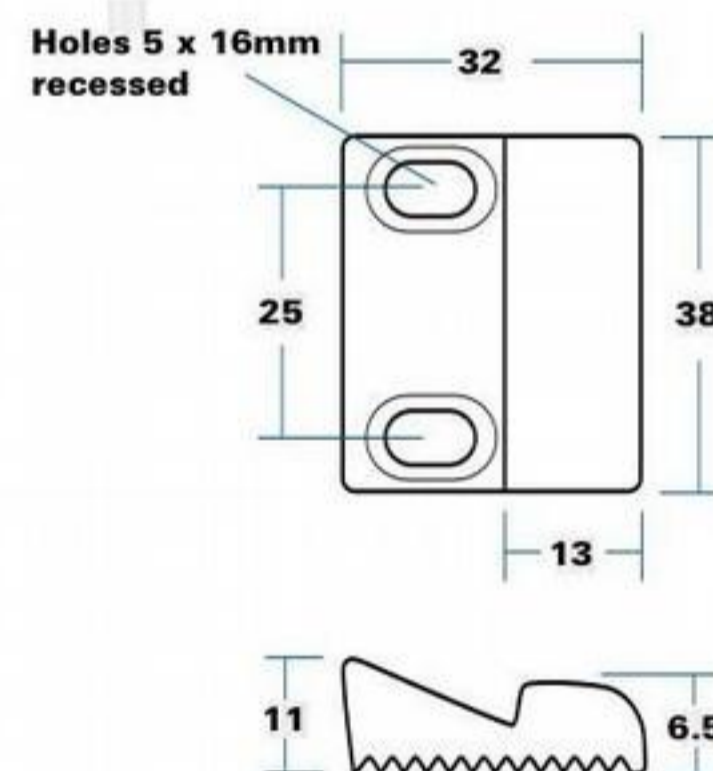

Useful 2-step striker with adjustable mounting holes. Use with most slam latches, 'paddle' latches, etc.

3/12341  
(Plain base)

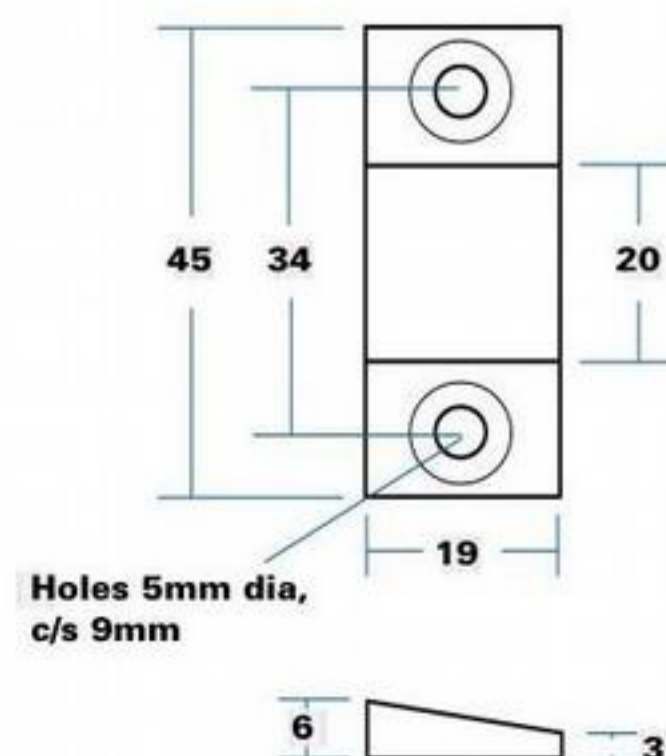

Standard with 2 & 3-way slam systems. Use with end-bolts, moulded slam latch 9/01530, etc.

F.A. Parkes (M.B.F) Limited  
Unit 4, Acorn Court  
Butts Street, Leigh  
Lancashire WN7 3AE

Tel. 01942 681 996  
[sales@faparkes.co.uk](mailto:sales@faparkes.co.uk)