



Buy on-line
at the FA Parkes
sales portal
the quickest
and most efficient
way to purchase
all your hardware
requirements; locks
handles, hinges
stays, gasketing
etc....

www.faparkes.co.uk
your one stop shop!



Double-sided 'FT'
keys only



1/25654 (Right-hand)
The connecting link between
'lock' and 'latch' points 'X'
& 'Y' can be clearly seen.

ORDERING CODE

'Freewheel' handles

1/25654 Flap handle, RH, black & chrome

1/25654B As above, all -black

1/25653 Flap handle, LH, black & chrome

1/25653B As above, all-black

1/25673 Flap handles, pair, black & chrome

1/25673B As above, all-black

'Isolated' handles

1/29344 Flap handle, RH, black & chrome

1/29344B As above, all black

1/29345 Flap handle, LH, black & chrome

1/29345B As above, all black

1/29346 Flap handles, pair, black & chrome

1/29346B As above, all black

INSIDE VIEW OF HANDLE (LH)

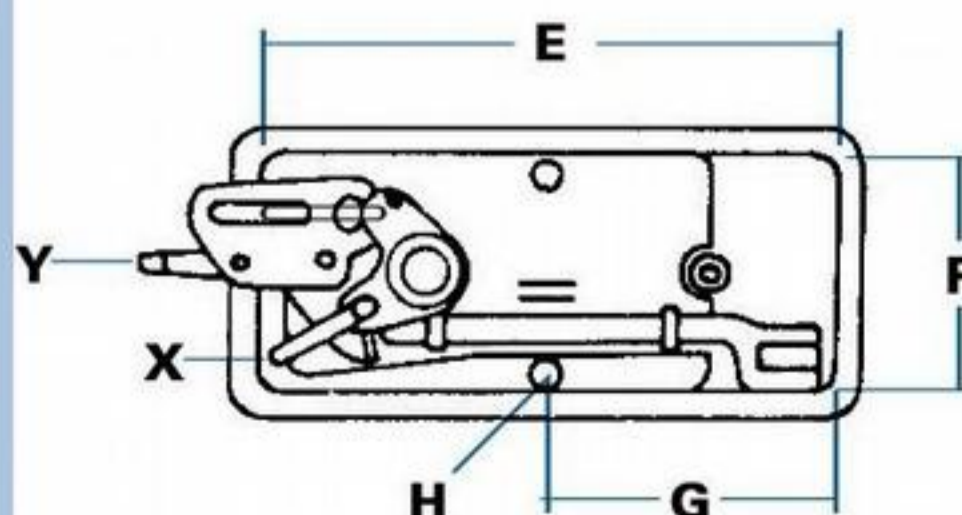

Studs are mounted in diecast bosses to clear operating plunger. Inside rim width is 6 mm. Recommended cut-out size 57 mm x 135 mm. Gasket rim width is 8 mm.

SPECIFICATION

RIGHT-HAND HANDLE ILLUSTRATED

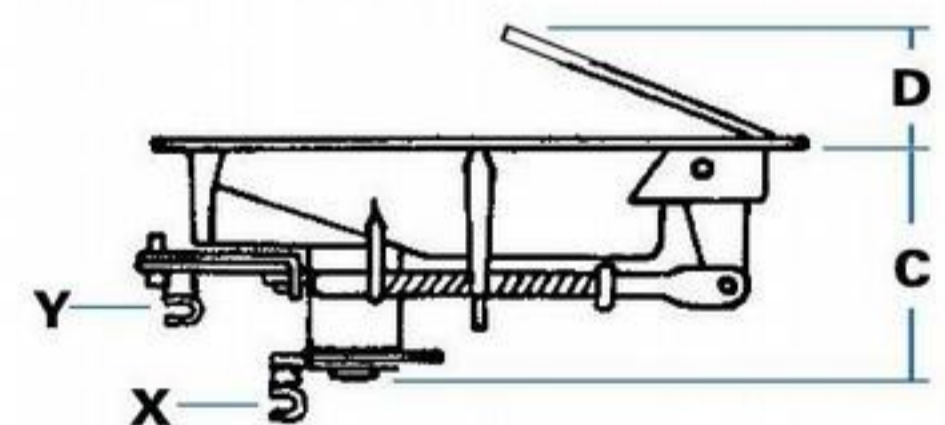
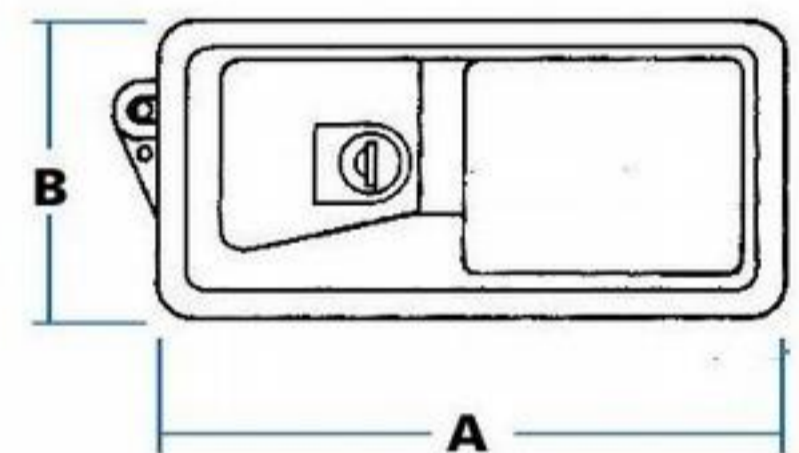

A Case length	145 mm
B Case width	67 mm
C Maximum depth	50 mm
D Maximum flap height	32 mm
E Inside length	133 mm
F Inside width	55 mm
G Location to studs	65 mm
H Studs	10-32 UNF x 10 mm
X Maximum travel of locking point when key is rotated	18 mm
Y Maximum travel of latching point when flap is lifted	15 mm

F.A. Parkes (M.B.F) Limited
Unit 4, Acorn Court
Butts Street, Leigh
Lancashire WN7 3AE

Tel. 01942 681 996
sales@faparkes.co.uk