



Buy on-line
at the FA Parkes
sales portal
the quickest
and most efficient
way to purchase
all your hardware
requirements; locks
handles, hinges
stays, gasketing
etc....

www.faparkes.co.uk
your one stop shop!

'FT' Keys
Optional



1/22788
'High-grip' handle

ORDERING CODE

1/22788	High-grip handle, locking, chrome
1/22788/01	As above, FS880
1/22789	High-grip handle, non-locking, chrome

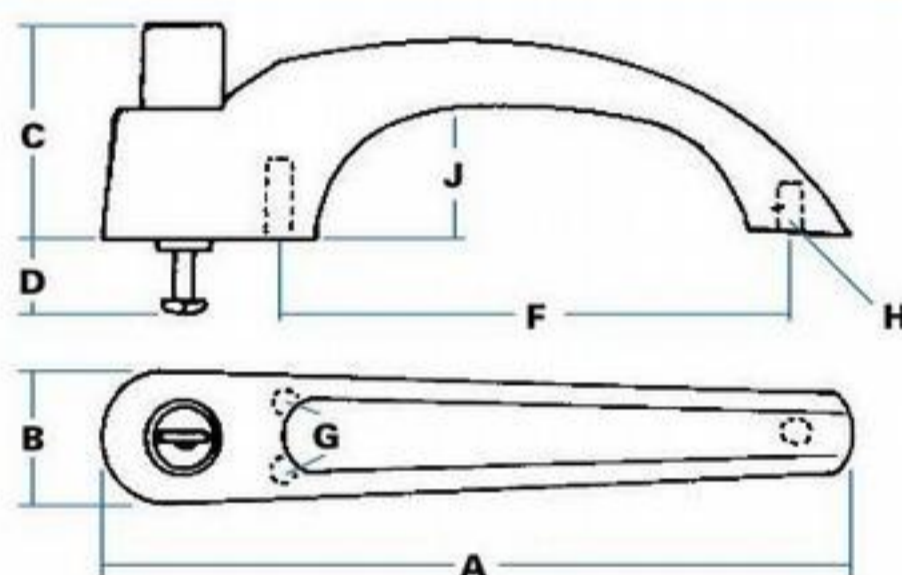

SPECIFICATION

A Length	175 mm
B Width (max)	33 mm
C Height (max)	52 mm
D Projection	15 mm
F Hole centres	120 mm
G Hole centres	16 mm
H Hole sizes	M6 x 19 mm
J Grip height	35 mm
K Travel (vertical)	15 mm

An adjustment nut allows simple, on-site control of depth of travel of plunger screw.



1/07986
'Classic' push-button handle



ORDERING CODE

1/07986	Classic handle, locking, chrome
1/07987	Classic handle, non-locking, chrome
1/07988	As 1/07986, paired

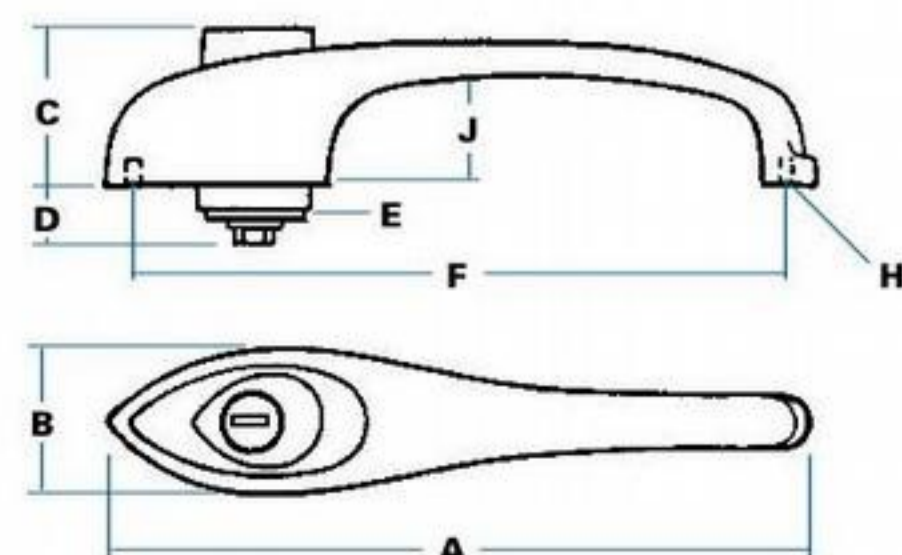

SPECIFICATION

A Length	158 mm
B Width	30 mm
C Height (max)	35 mm
D Projection (rest)	12 mm
E Diameter	24 mm
F Hole centres	145 mm
H Hole sizes	1/4 BSF x 10 mm
J Grip height	19 mm
K Travel (vertical)	8 mm

F.A. Parkes (M.B.F) Limited
Unit 4, Acorn Court
Butts Street, Leigh
Lancashire WN7 3AE

Tel. 01942 681 996
sales@faparkes.co.uk